

節目 知識好好玩

EP08 | 台灣這美麗的矽島——聊 一聊半導體物理

主持人 | 張嘉泓

單曲長度 | 00:25:46 發布時間 | 2021-08-03

#科學 #張嘉泓 #物理好好玩 #晶圓 #半導體
#矽島 #台積電 #電洞 #自動計算機



查看節目資訊

開始播放

導體內有可以自由移動的電荷。

若有電場、及電位差，正電荷會移動，由高電位移向低電位。

負電荷會移動，由低電位移向高電位，直到電場為零。

但有時可以讓電位差一直持續，電荷就可以繼續移動。

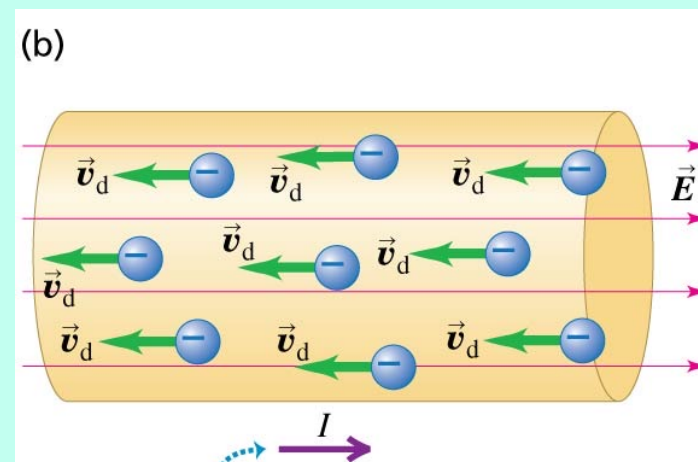
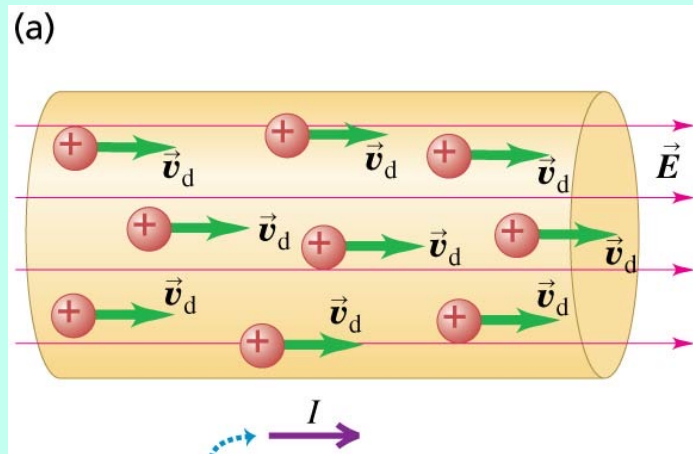
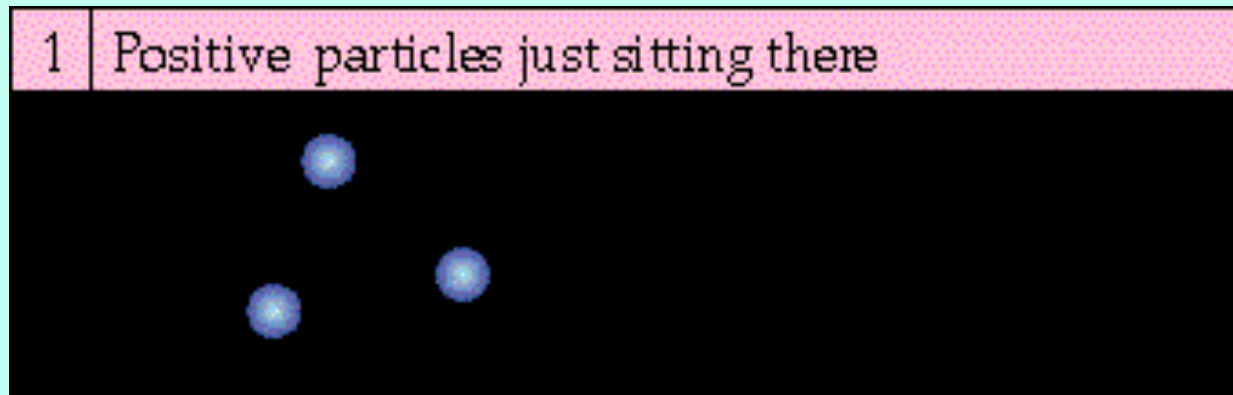



Alessandro Giuseppe Antonio Anastasio Volta
(1745-1827)



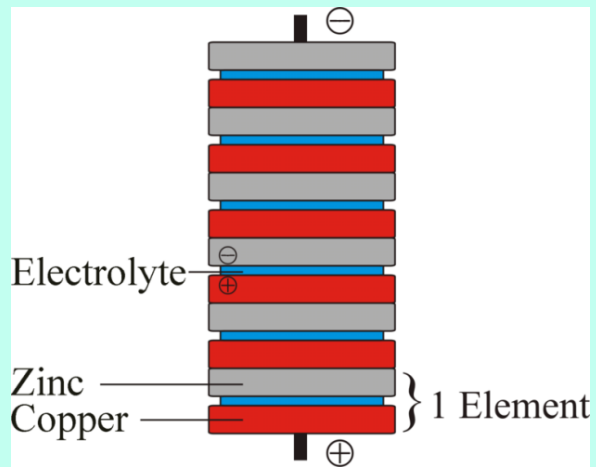

Zinc 鋅
Sulfuric acid

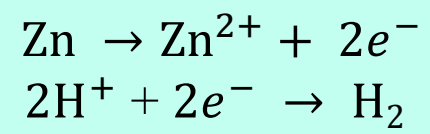

傳導的導線

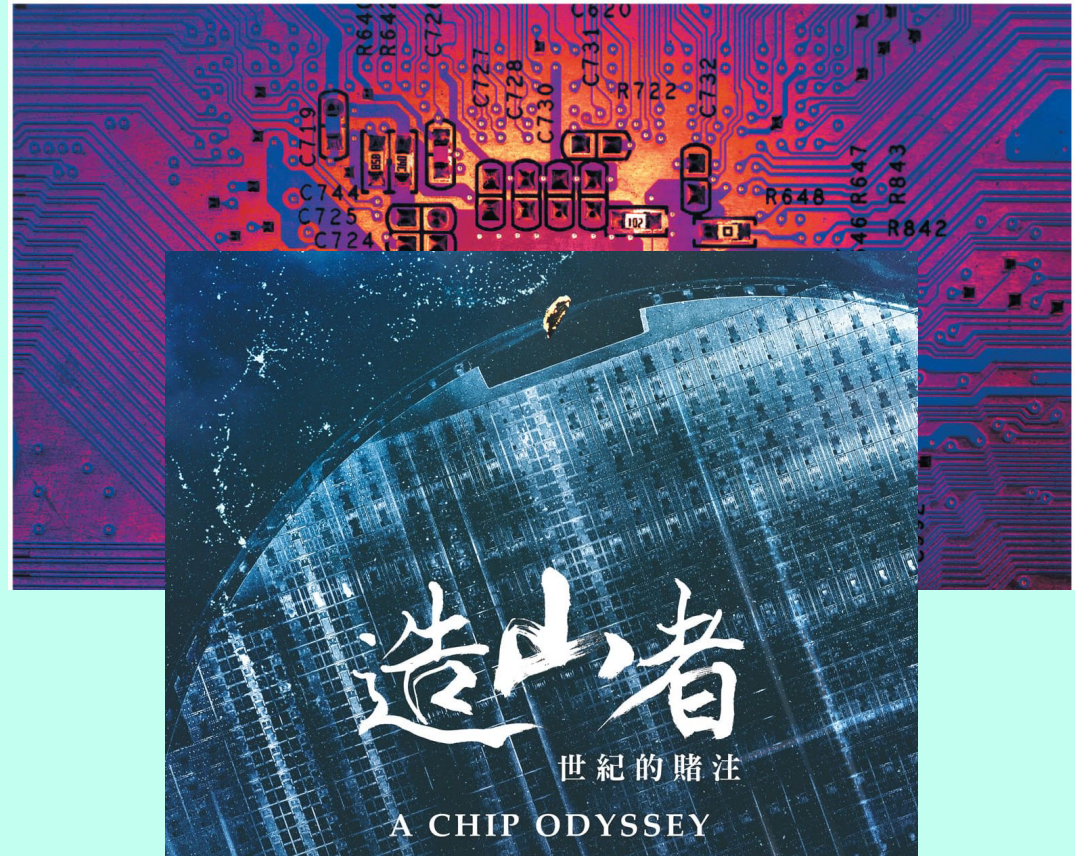
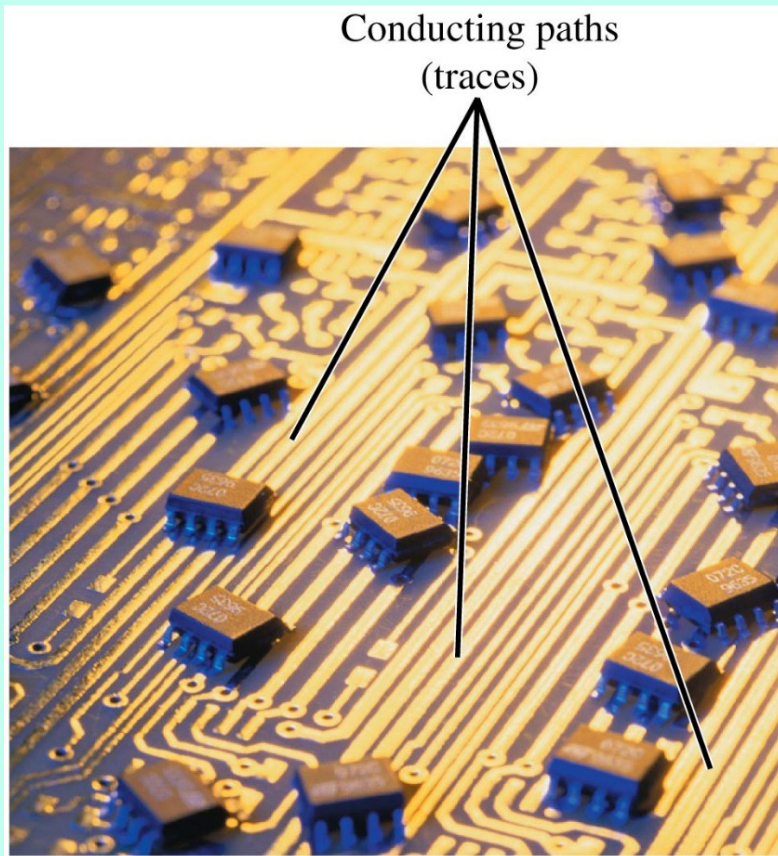

導體內的電流是在外加電場下，正電荷朝電場方向進行飄移運動！
在大部分導體中，是電子朝電場反方向漂移運動！漂移速度大約為 v_d 。
用上圖正電荷來代表，效果一樣。

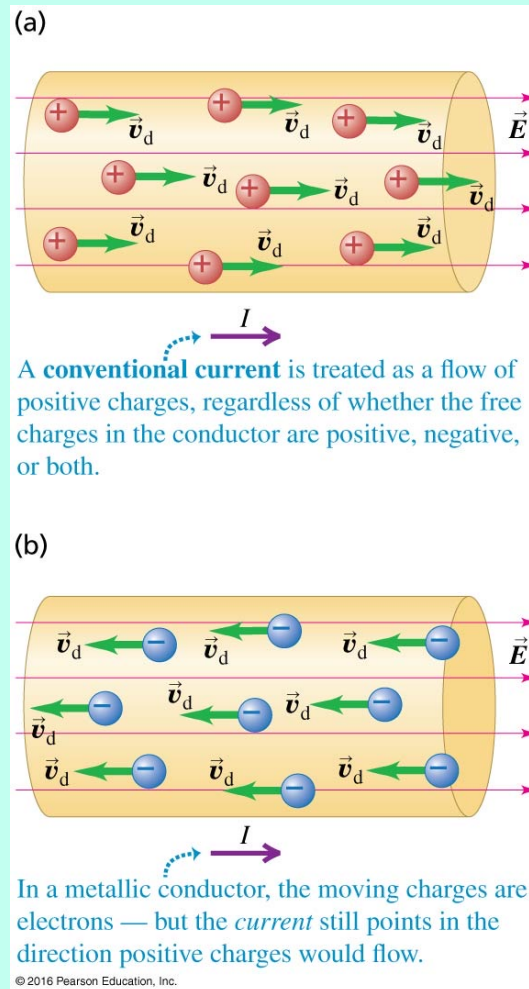

電流為單位時間流過某一截面積 A 的電荷量！

這等於一段時間內流過截面積 A 的電荷量 q 除以時間間隔 Δt ！

$$i = \frac{q}{\Delta t} \quad \text{注意電流不是向量！}$$

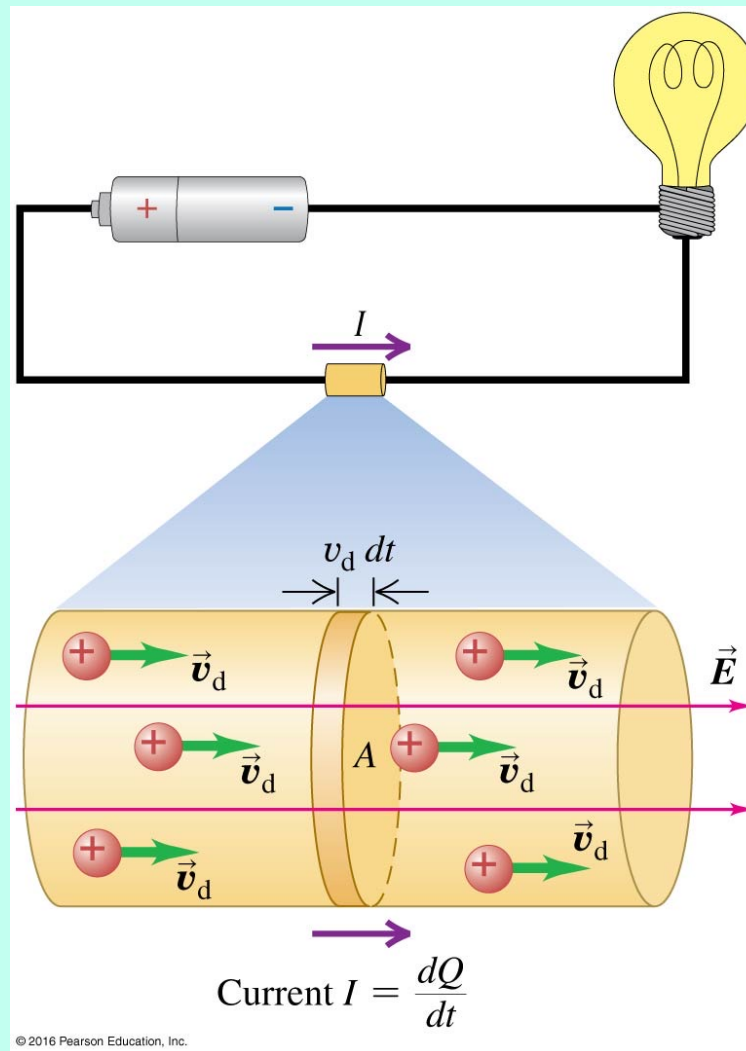

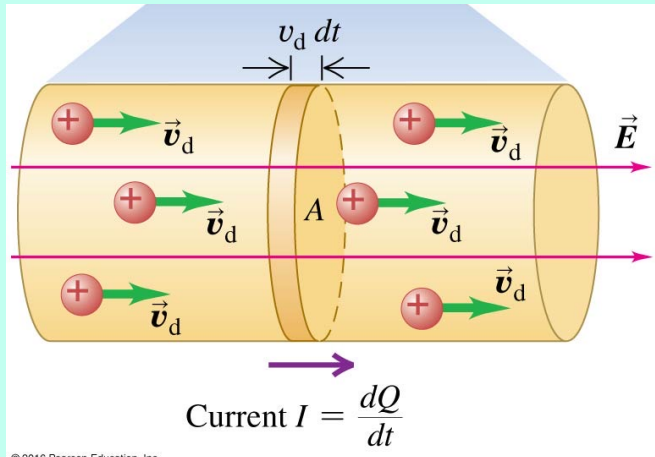

電流一般會與垂直截面積成正比。

將電流除以面積，才代表當地電荷的流動。

$$j = \frac{i}{A} \quad \text{稱為電流密度：單位面積的電流。}$$

電流密度代表當地電荷流動，可以給予一方向！

定電荷流動的方向為電流密度的方向

$$j \rightarrow \vec{j}$$

導體各處都可以有一個當地的電流密度。

$$\vec{j} \rightarrow \vec{j}(\vec{r})$$

電流密度是位置 \vec{r} 的函數

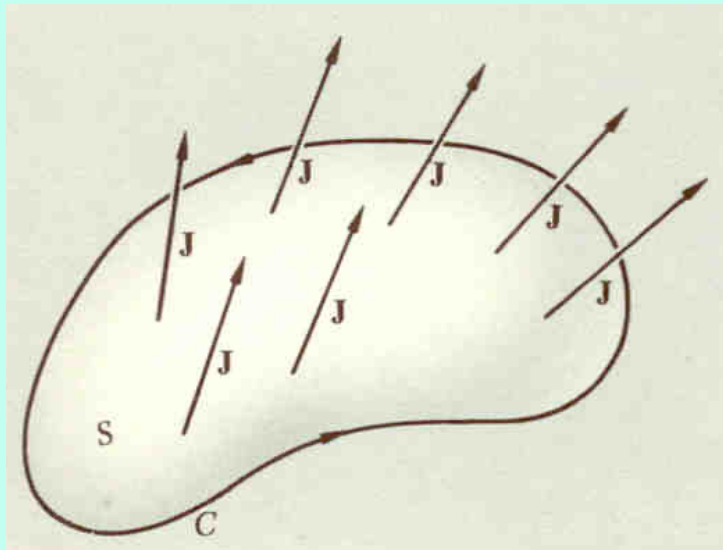

電流密度 j 就是電荷流動的通量！如同流體的流量是一樣的！
 有了電流密度即可計算單位時間通過任一平面的電荷量。

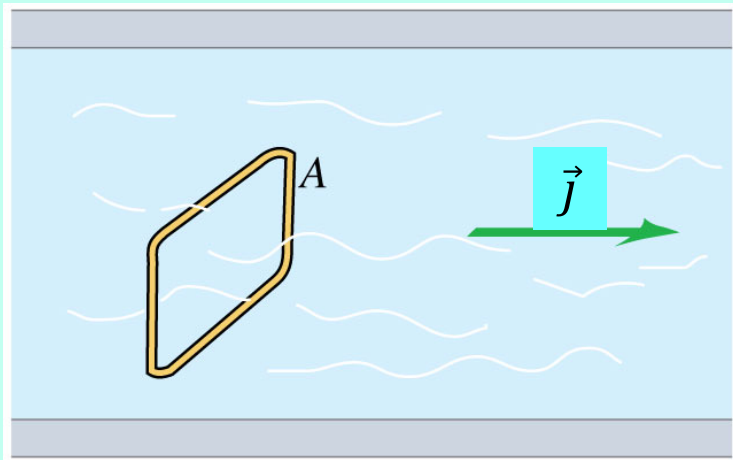

如果平面垂直於 j ，

$$j = \frac{i}{A}$$

$$i = jA$$

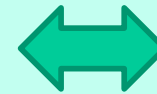

$$\phi = EA$$

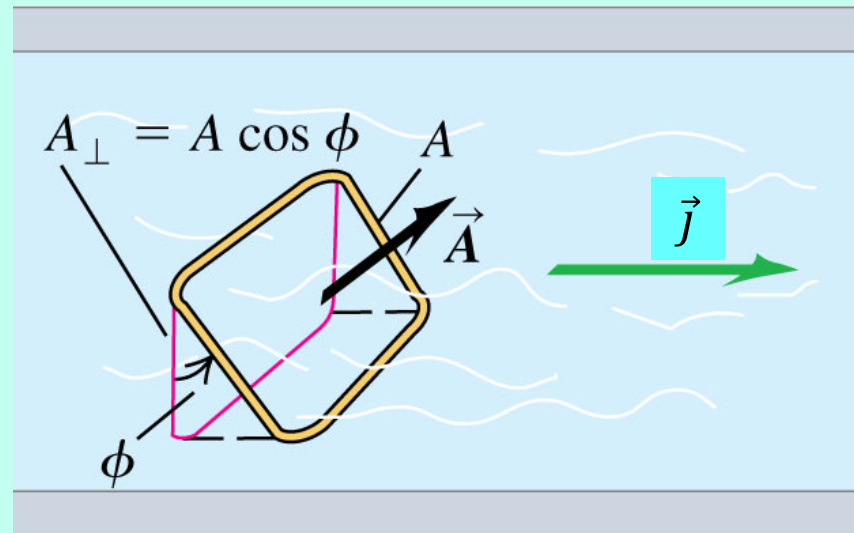

如果平面不是垂直於 j ，

$$i = jA_{\perp} = j \cdot A \cos \theta = \vec{j} \cdot \vec{A}$$

電流即是電流密度對該平面的通量！

$$i = \vec{j} \cdot \vec{A}$$



$$\Phi_E = \vec{E} \cdot \vec{A}$$

電流也可以是連續的，在不同位置電荷流動的方向可以不一樣， $\vec{j}(\vec{r})$

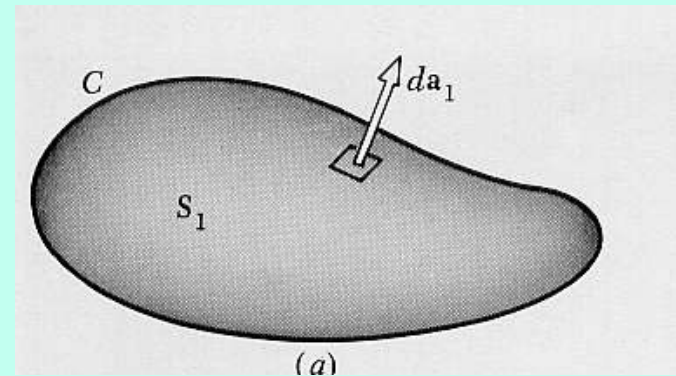
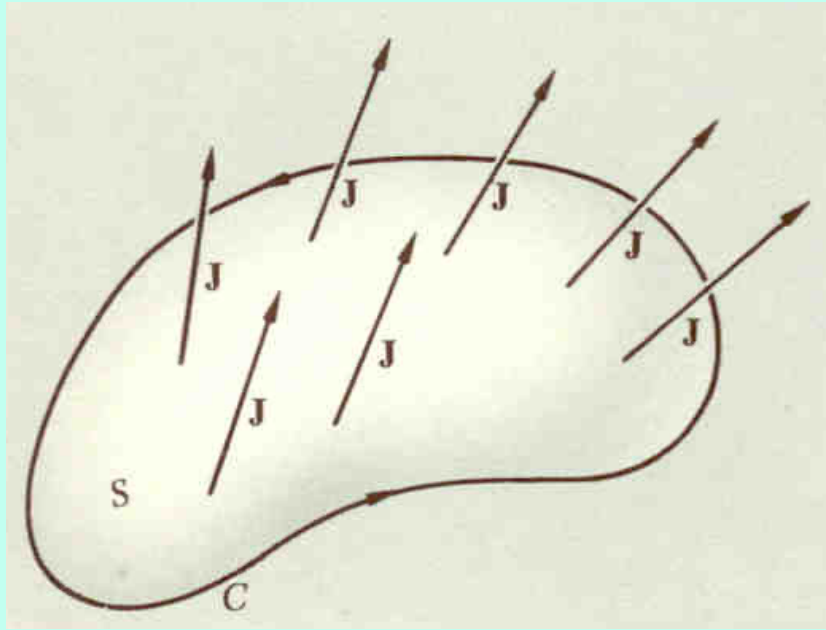

將曲面切成一個一個的無限小平面，
在每一小片平面上，電流都是電流密度對該平面的通量！
加總後，通過曲面的總電流就是電流密度對該曲面的總通量

$$i = \int \vec{j} \cdot d\vec{A}$$

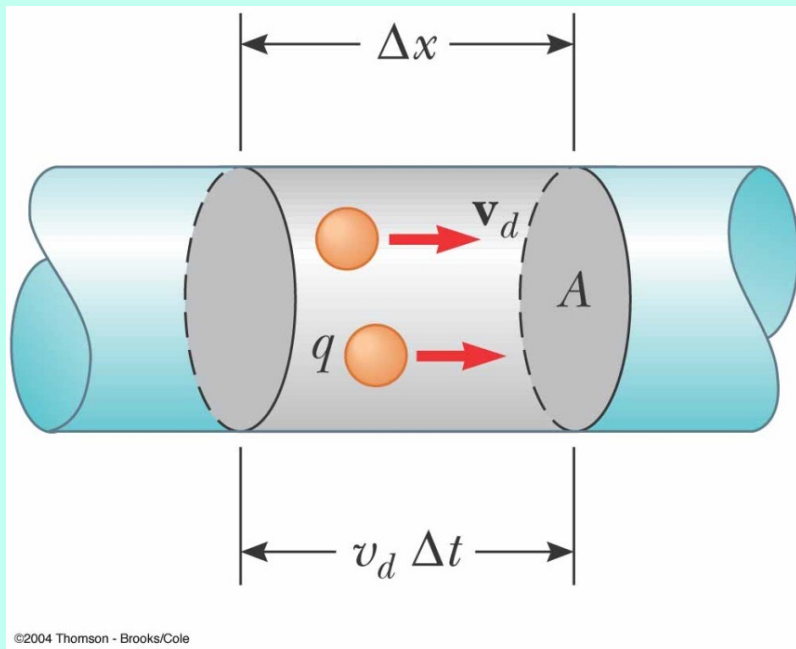

電流密度大小由漂移速度 v_d 決定：

取 Δt ，在此時間內通過截面 A 的電荷：

一定就在左圖灰色體積範圍內：

$$q = (A\Delta x) \cdot ne = neAv_d\Delta t$$

$$i = \frac{q}{\Delta t} = neAv_d$$

電流密度為單位面積的電流。

$$j = \frac{i}{A} = nev_d$$

電流密度與平均漂移速度成正比。

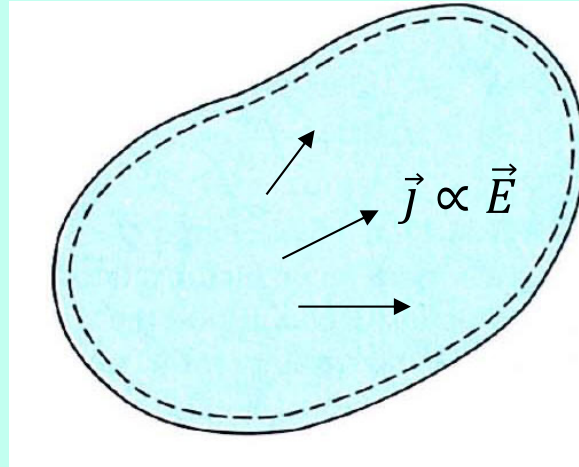

Georg Simon Ohm



實驗發現，在導體中電場與電流密度成正比！

$\vec{E} = \rho \vec{j}$ ρ 是電阻率 Resistivity，是材料的性質。

歐姆定律

適用於任意形狀、甚至大片導體內的電流流動的版本！

有了這個定律，導體內的電場直接可以由電流得到。

TABLE 25.1 Resistivities at Room Temperature (20°C)

Substance		ρ ($\Omega \cdot \text{m}$)	Substance		ρ ($\Omega \cdot \text{m}$)
Conductors			Semiconductors		
Metals	Silver	1.47×10^{-8}	Pure carbon (graphite)	3.5×10^{-5}	
	Copper	1.72×10^{-8}	Pure germanium	0.60	
	Gold	2.44×10^{-8}	Pure silicon	2300	
	Aluminum	2.75×10^{-8}	Insulators		
	Tungsten	5.25×10^{-8}	Amber	5×10^{14}	
	Steel	20×10^{-8}	Glass	$10^{10} - 10^{14}$	
	Lead	22×10^{-8}	Lucite	$> 10^{13}$	
	Mercury	95×10^{-8}	Mica	$10^{11} - 10^{15}$	
	Alloys	Manganin (Cu 84%, Mn 12%, Ni 4%)	44×10^{-8}	Quartz (fused)	75×10^{16}
Constantan (Cu 60%, Ni 40%)		49×10^{-8}	Sulfur	10^{15}	
Nichrome		100×10^{-8}	Teflon	$> 10^{13}$	
			Wood	$10^8 - 10^{11}$	

如果導體是導線，電流只能沿導線方向。

因此電場、電位差都只能沿導線方向。

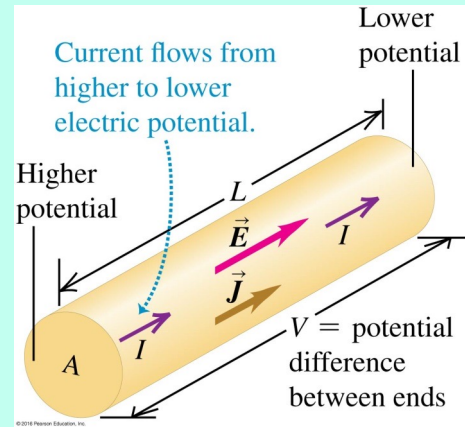

均勻導線內的電流流動

$$E = \rho \cdot j$$

$$\frac{V}{L} = \rho \cdot \frac{I}{A} \quad V, I \text{ 是描述導線電流比較方便的量！}$$

$$V = \frac{\rho L}{A} \cdot I = RI \quad \text{電阻} R \text{ 是一元件的性質}$$

$$V = RI \quad \text{適用於均勻導線內的歐姆定律}$$

電流由電位差決定，（導線內部）電位差由電流決定！

沿任意封閉導線的總電位差必為零。

$$\sum_i \Delta V_i = \Delta V = 0$$

Kirchhoff's loop law

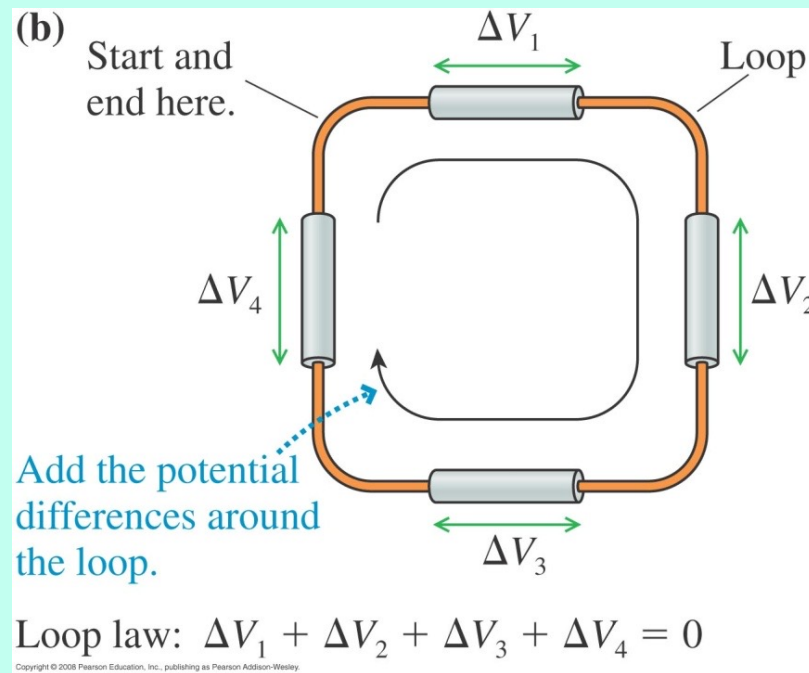

(a)

Ohmic resistor (e.g., typical metal wire): At a given temperature, current is proportional to voltage.

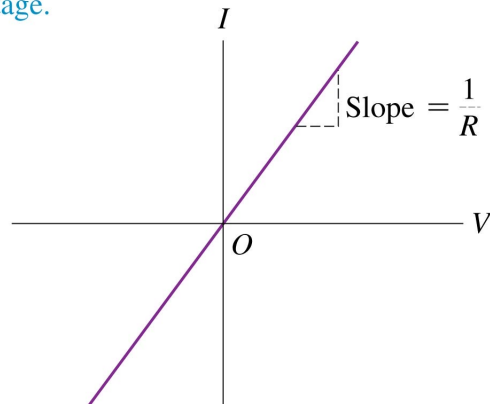

© 2016 Pearson Education, Inc.

歐姆定律也適用於電路元件電阻器。
電阻器有特定的電阻值 R 。

$$V = RI$$

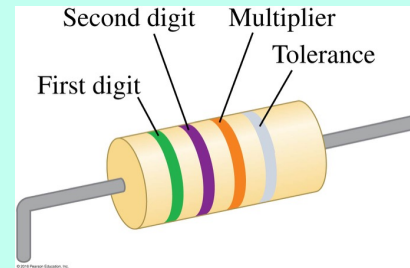

電阻器雙向是對等的。

(b)

Semiconductor diode: a nonohmic resistor

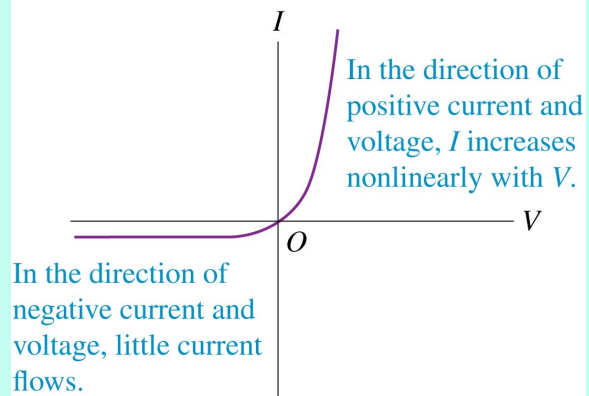

© 2016 Pearson Education, Inc.

半導體二極體的電阻值與方向有關。

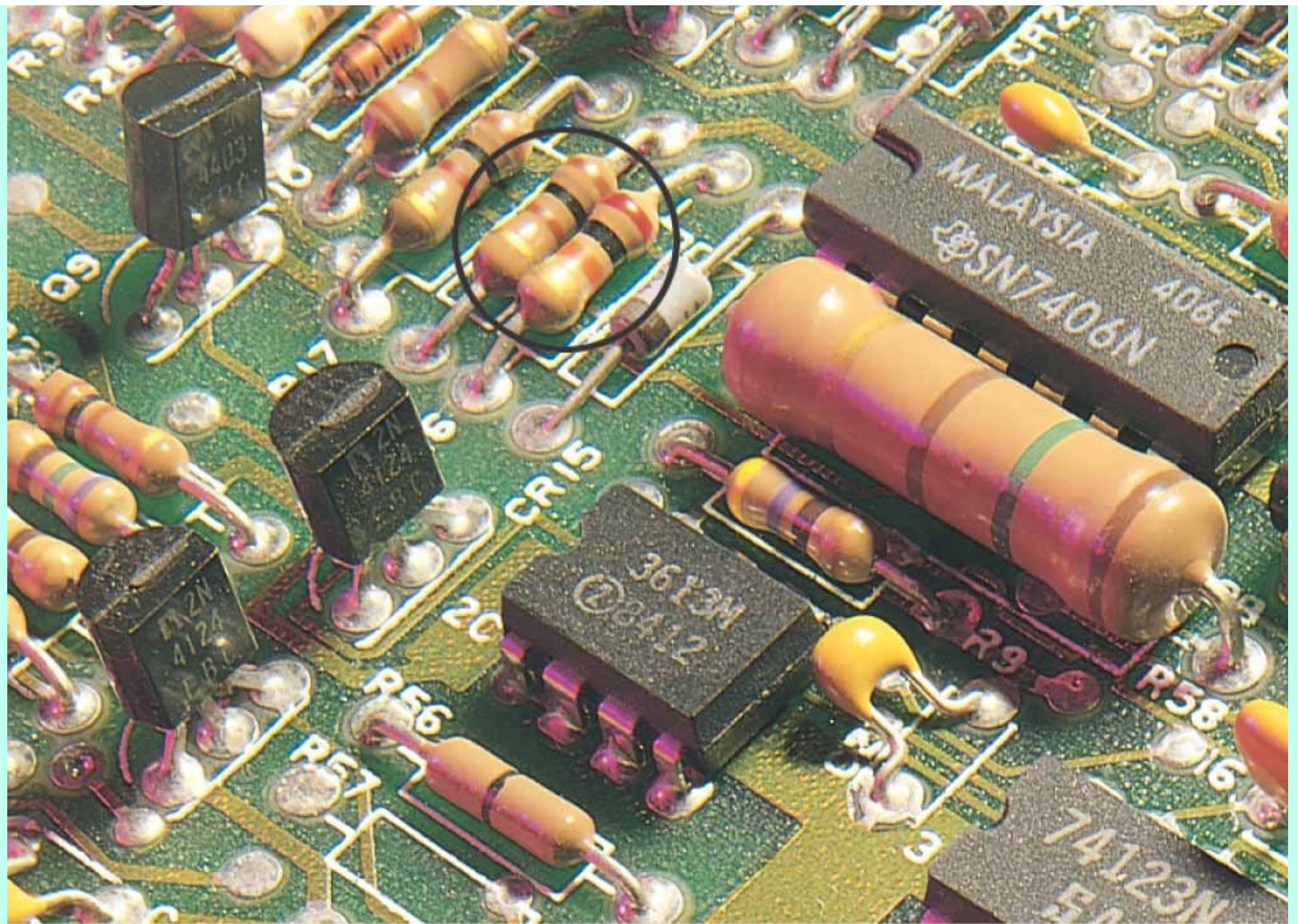

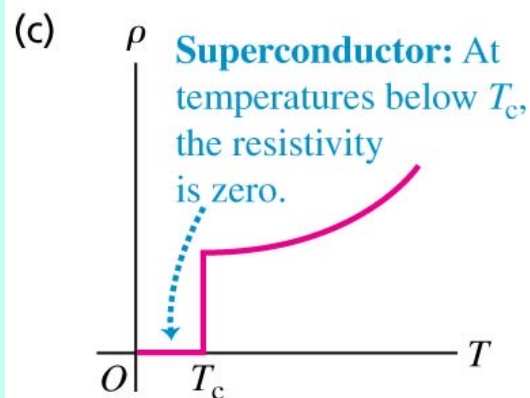
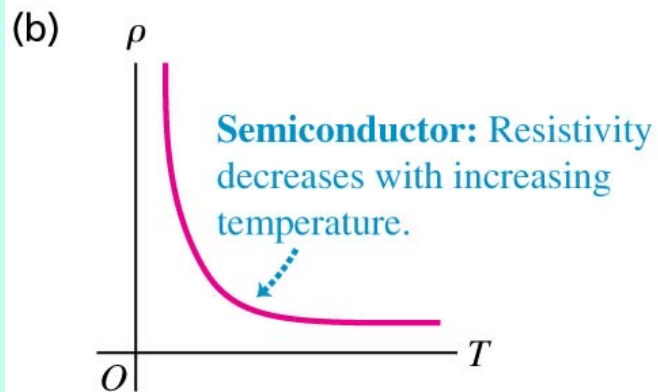
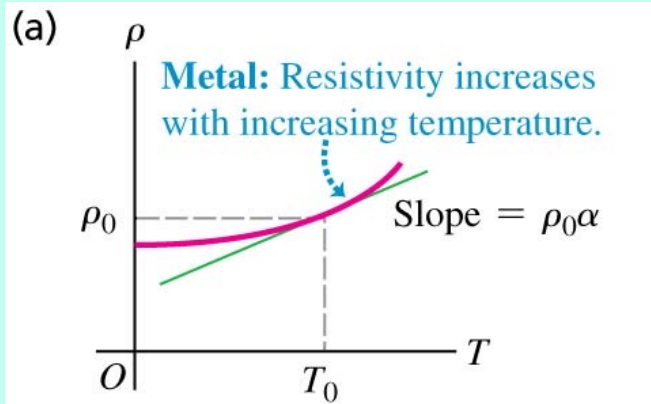

© 2016 Pearson Education, Inc.

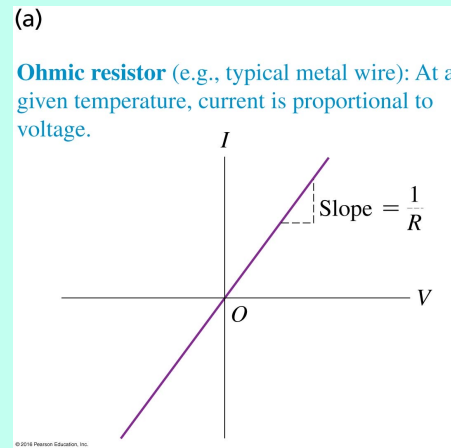

$$V = RI$$

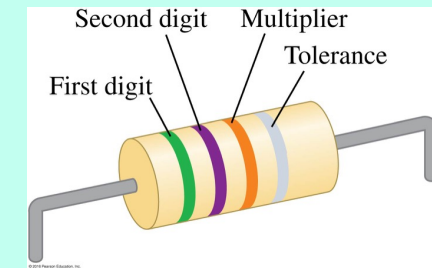

電阻值也與溫度有關。

導體電阻隨溫度增加。

但半導體電阻隨溫度迅速減小後持穩。

超導體電阻在低於臨界溫度後會趨近於零。

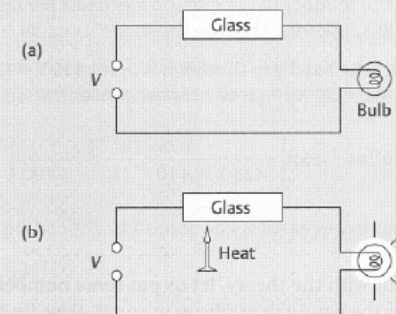
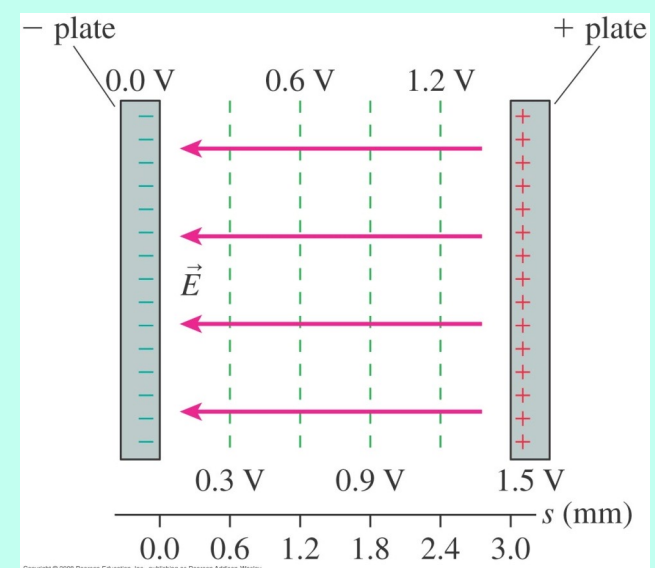
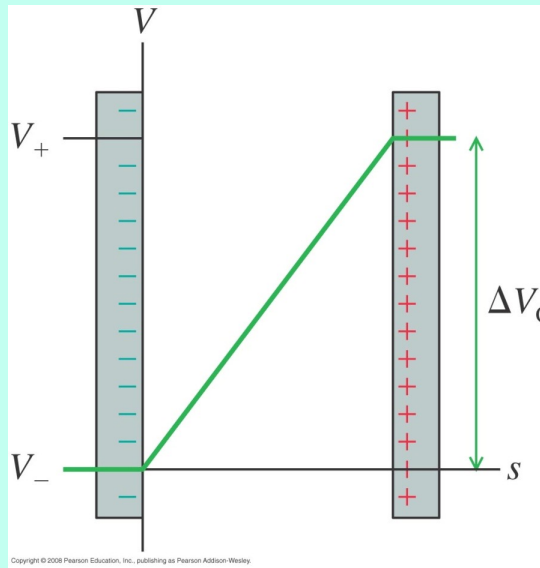
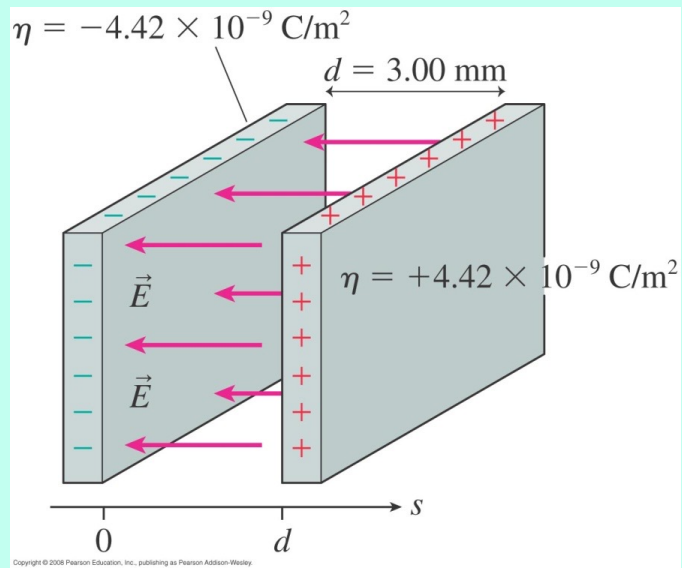

Figure 5.7 (a) A simple circuit consisting of a glass bar in series with a light bulb. At room temperature the bulb does not light because glass is an insulator. (b) But if the glass bar is heated (e.g. using a Bunsen burner), the conductivity of the glass increases and the bulb lights.



兩片帶相反電性的平板之間的電場是均勻的。

平板外電場為零，如此就不會干擾其他元件。

兩代電板間有一電位差： **$V = Ed$**

如要維持此電量與電場，必須加一電壓！

電容為儲存電場的裝置。

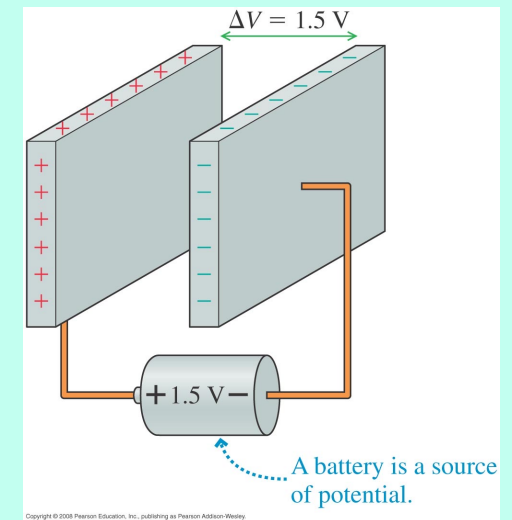



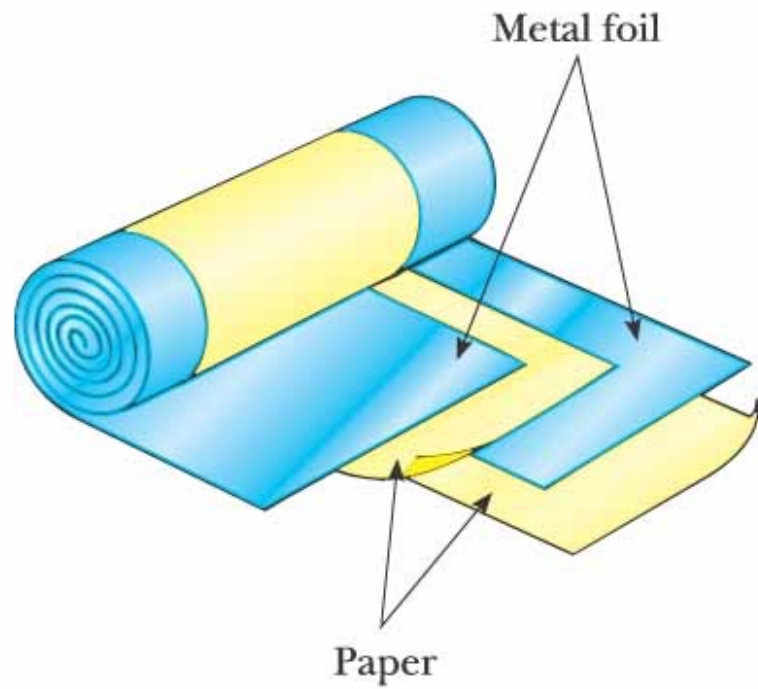

(a)

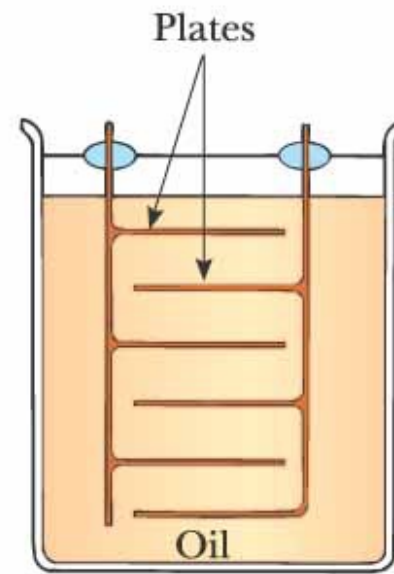

(b)

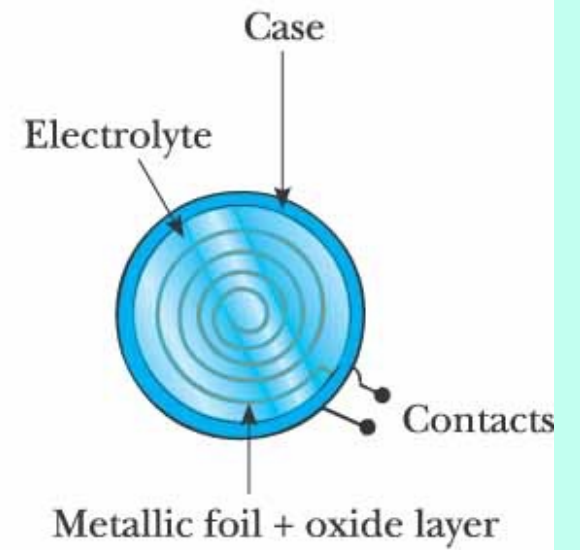

(c)

Capacitor
symbol



Battery
symbol

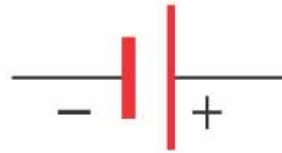

Switch
symbol



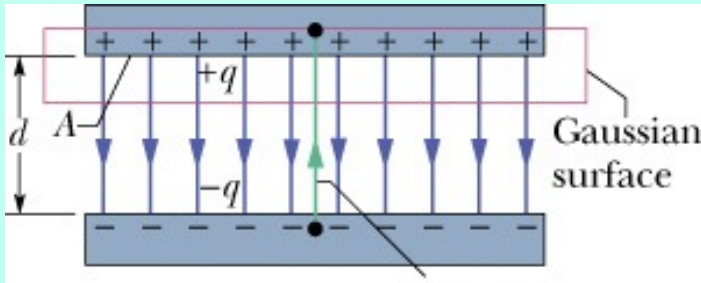

$$V = Ed$$

$$E = \frac{\sigma}{\epsilon_0} = \frac{Q}{A\epsilon_0}$$

$$V = \frac{d}{A\epsilon_0} Q = \frac{Q}{C}$$

$$C = \frac{A\epsilon_0}{d}$$

$$Q = CV$$

類似的公式也適用於圓柱體電容。

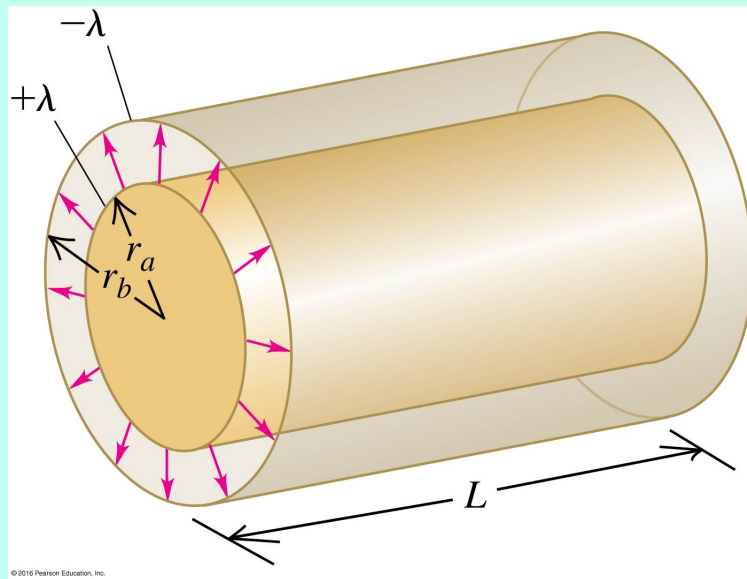

$$C = \frac{Q}{V} = \frac{\lambda L}{\frac{\lambda}{2\pi\epsilon_0} \ln \frac{r_b}{r_a}}$$

電容的電荷正比於電壓。 $Q = CV$

Battery 電池

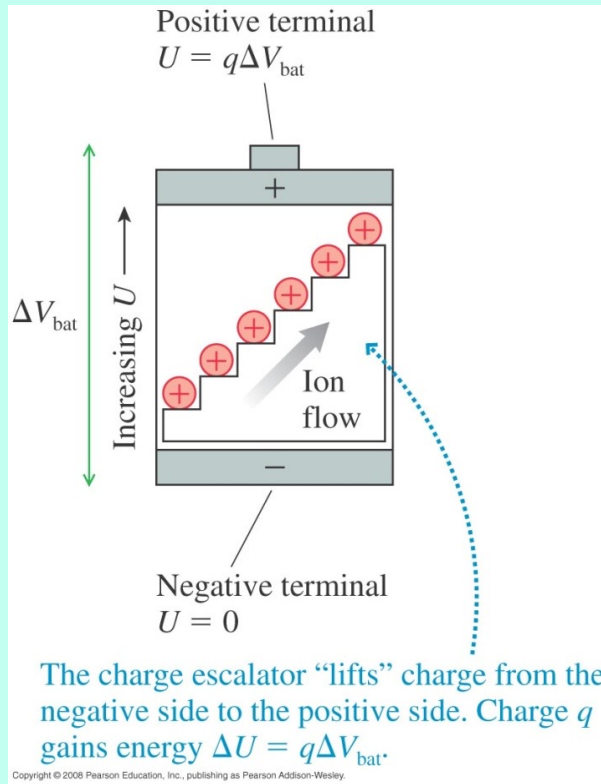

電子通過電池後電位增加！
因此連著電池的元件會維持一電位差。

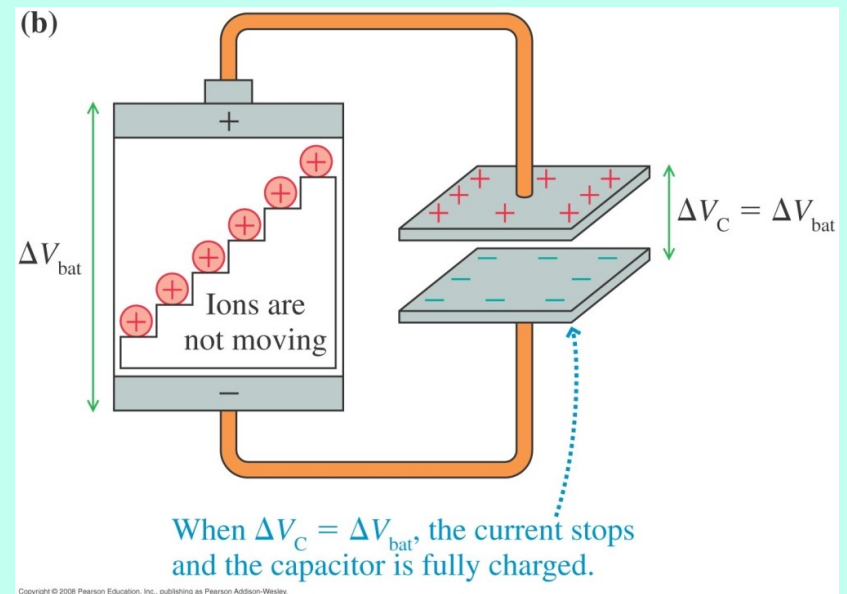
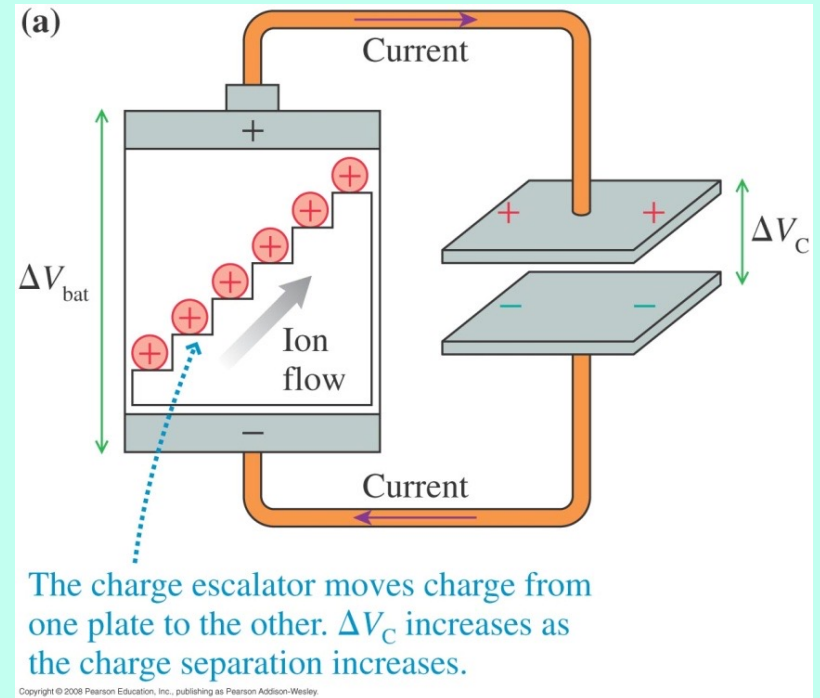



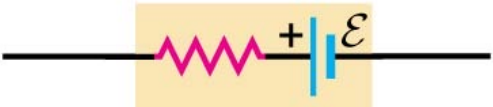

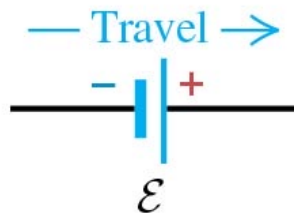

TABLE 25.4 Symbols for Circuit Diagrams

	Conductor with negligible resistance
	Resistor
	Source of emf (longer vertical line always represents the positive terminal, usually the terminal with higher potential)
	Source of emf with internal resistance r (r can be placed on either side)
or 	
	Voltmeter (measures potential difference between its terminals)
	Ammeter (measures current through it)

(a) Sign conventions for emfs

$+\mathcal{E}$: Travel direction
from $-$ to $+$:



$-\mathcal{E}$: Travel direction
from $+$ to $-$:

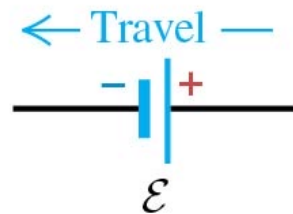

(b) Sign conventions for resistors

$+IR$: Travel *opposite*
to current direction:

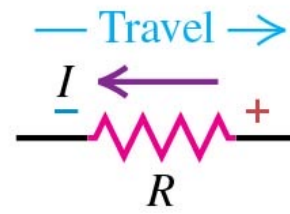

$-IR$: Travel *in*
current direction:

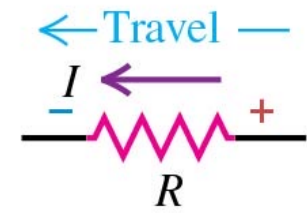

在電路中，連續的導線一直是等電位！

每一電路元件，都會有一由電流或電荷決定的電位差。

沿任何封閉導線的總電位差必為零。

$$\sum_i \Delta V_i = \Delta V = 0 \quad \text{Kirchhoff's loop law}$$

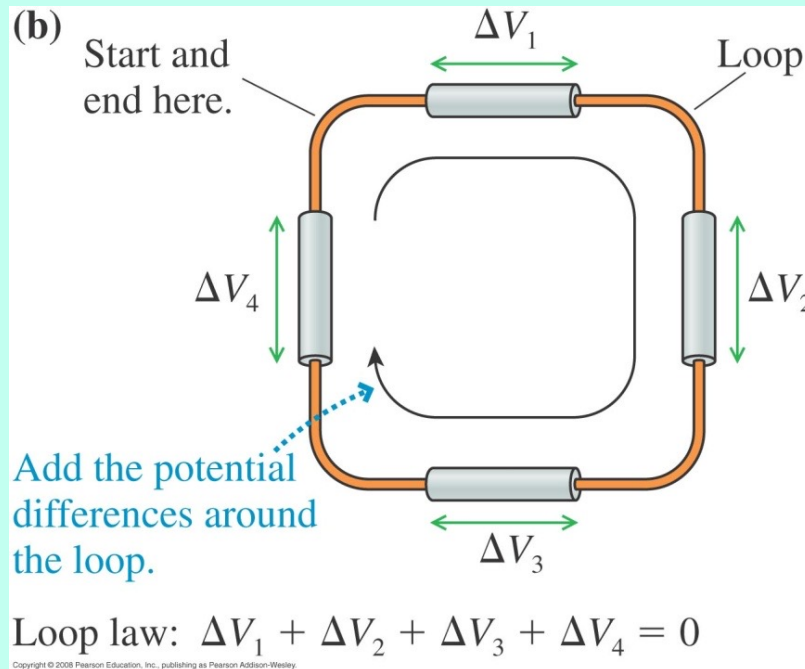

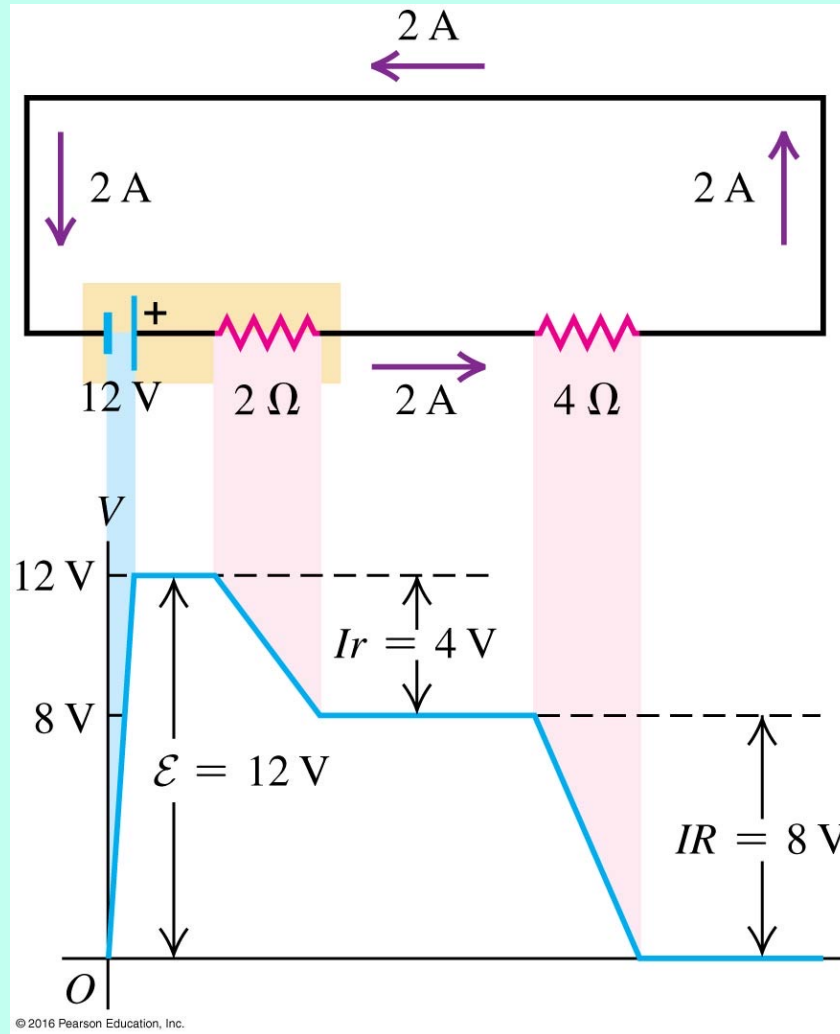

$$12.0\text{ V} - I \cdot 2\ \Omega - I \cdot 4\ \Omega = 0$$

$$I = 2.0\text{ A}$$

沿任何封閉路徑的總電位差必為零。

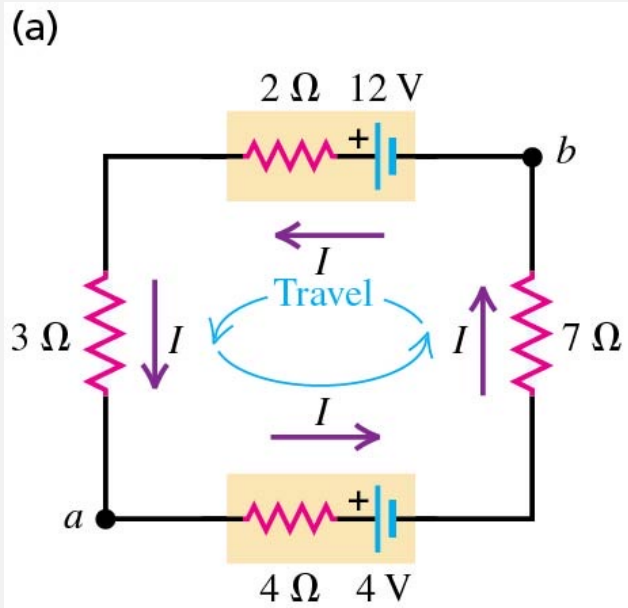

© 2016 Pearson Education, Inc.

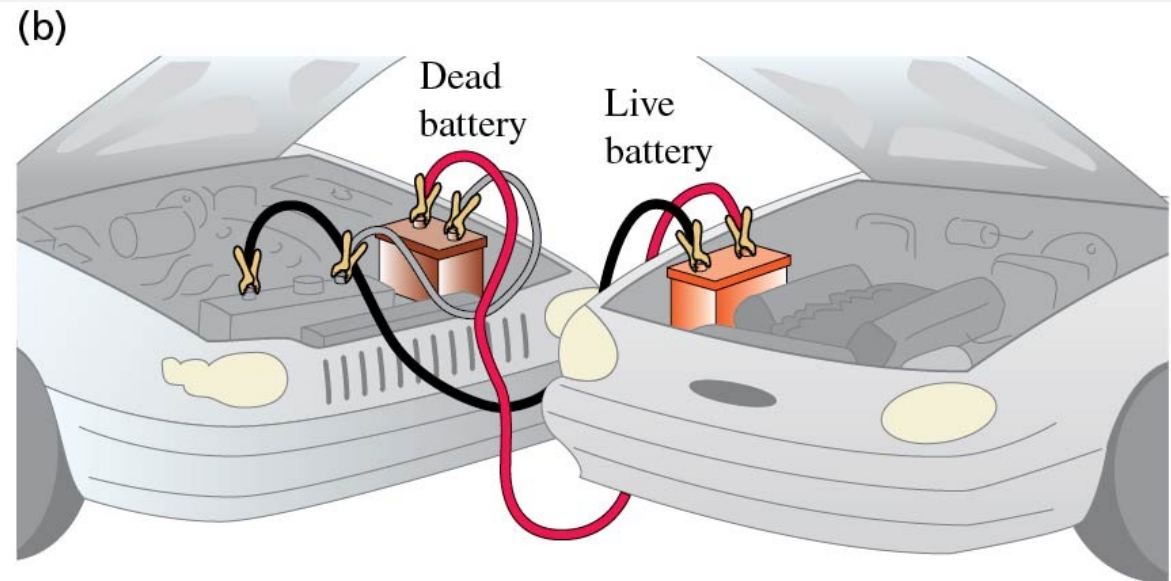

(b) Applying the junction rule to point a eliminates I_3 .

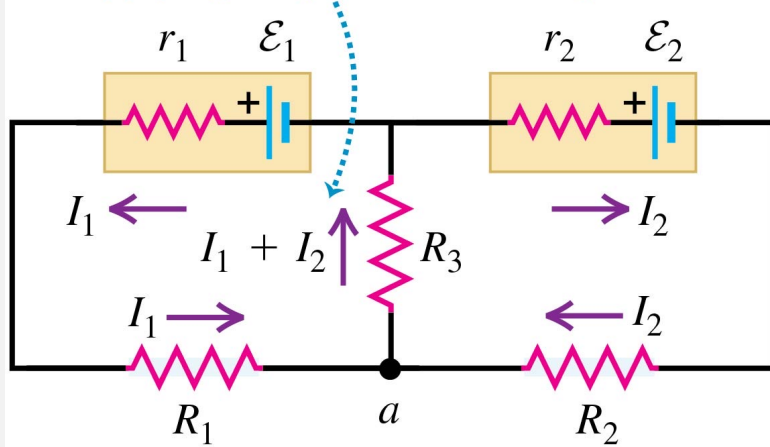

© 2016 Pearson Education, Inc.

(a) Kirchhoff's junction rule

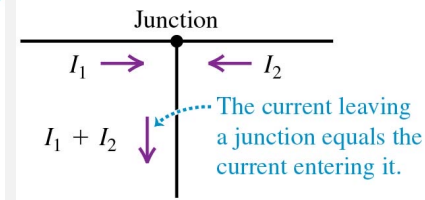

© 2016 Pearson Education, Inc.

(b) Water-pipe analogy

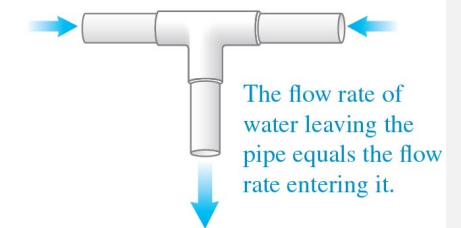

在電路交點處電荷不會累積。
 流入交點的電流必須等於流出的電流。

沿任何封閉路徑的總電位差必為零。

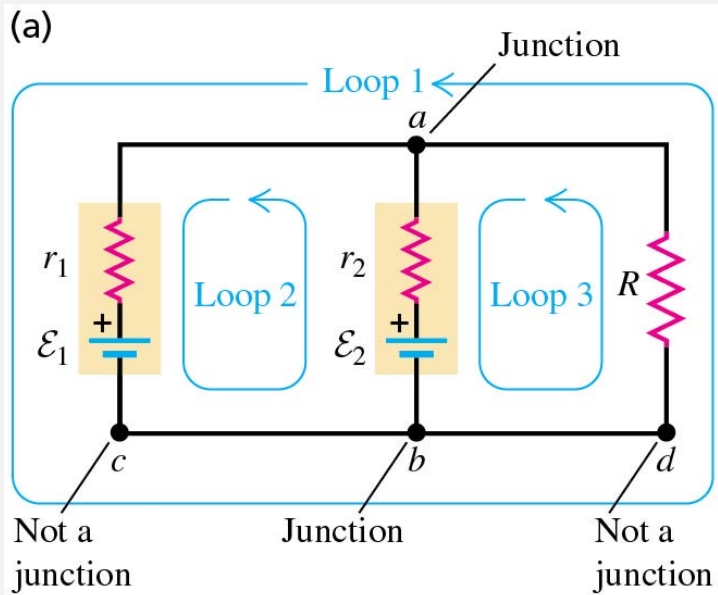

沿任何封閉路徑的總電位差必為零。
 流入交點的電流必須等於流出的電流。

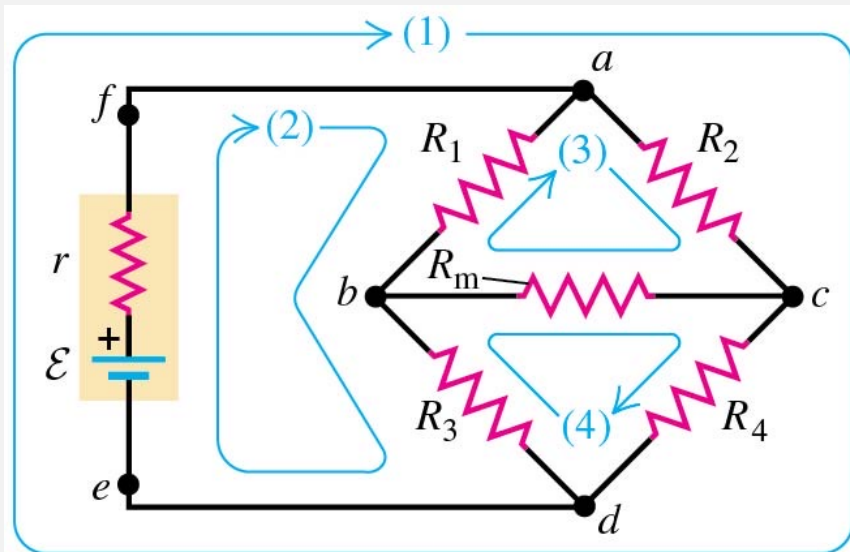

EXAMPLE 26.4 Charging a battery

WITH **✓** VARIATION PROBLEMS

In the circuit shown in **Fig. 26.11**, a 12 V power supply with unknown internal resistance r is connected to a run-down rechargeable battery with unknown emf \mathcal{E} and internal resistance $1\ \Omega$ and to an indicator light bulb of resistance $3\ \Omega$ carrying a current of 2 A. The current through the run-down battery is 1 A in the direction shown. Find r , \mathcal{E} , and the current I through the power supply.

IDENTIFY and SET UP This circuit has more than one loop, so we must apply both the junction and loop rules. We assume the direction of the current through the 12 V power supply, and the polarity of the run-down battery, to be as shown in **Fig. 26.11**. There are three target variables, so we need three equations.

EXECUTE We apply the junction rule, Eq. (26.5), to point a :

$$-I + 1\ \text{A} + 2\ \text{A} = 0 \quad \text{so} \quad I = 3\ \text{A}$$

Figure 26.11 In this circuit a power supply charges a run-down battery and lights a bulb. An assumption has been made about the polarity of the emf \mathcal{E} of the battery. Is this assumption correct?

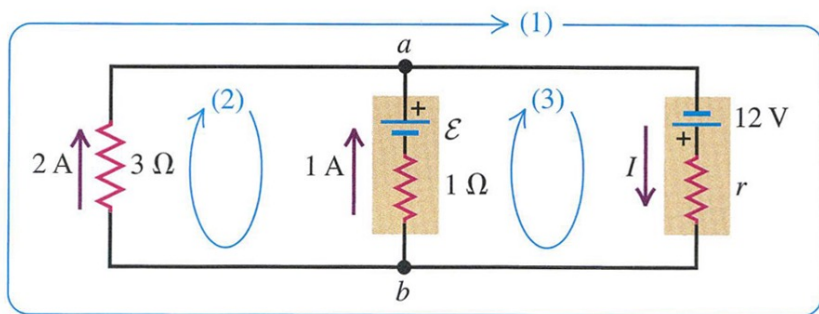

To determine r , we apply the loop rule, Eq. (26.6), to the large, outer loop (1):

$$12\ \text{V} - (3\ \text{A})r - (2\ \text{A})(3\ \Omega) = 0 \quad \text{so} \quad r = 2\ \Omega$$

To determine \mathcal{E} , we apply the loop rule to the left-hand loop (2):

$$-\mathcal{E} + (1\ \text{A})(1\ \Omega) - (2\ \text{A})(3\ \Omega) = 0 \quad \text{so} \quad \mathcal{E} = -5\ \text{V}$$

The negative value for \mathcal{E} shows that the actual polarity of this emf is opposite to that shown in **Fig. 26.11**. As in **Example 26.3**, the battery is being recharged.

EVALUATE Try applying the junction rule at point b instead of point a , and try applying the loop rule counterclockwise rather than clockwise around loop (1). You'll get the same results for I and r . We can check our result for \mathcal{E} by using loop (3):

$$12\ \text{V} - (3\ \text{A})(2\ \Omega) - (1\ \text{A})(1\ \Omega) + \mathcal{E} = 0$$

which again gives us $\mathcal{E} = -5\ \text{V}$.

As an additional check, we note that $V_{ba} = V_b - V_a$ equals the voltage across the $3\ \Omega$ resistance, which is $(2\ \text{A})(3\ \Omega) = 6\ \text{V}$. Going from a to b by the right-hand branch, we encounter potential differences $+12\ \text{V} - (3\ \text{A})(2\ \Omega) = +6\ \text{V}$, and going by the middle branch, we find $-(-5\ \text{V}) + (1\ \text{A})(1\ \Omega) = +6\ \text{V}$. The three ways of getting V_{ba} give the same results.

KEYCONCEPT In any circuit that has more than one loop, Kirchhoff's junction rule applies: At each junction, the sum of the currents into the junction must be zero.

EXAMPLE 26.6 A complex network

WITH  VARIATION PROBLEMS

Figure 26.12 shows a “bridge” circuit of the type described at the beginning of this section (see Fig. 26.6b). Find the current in each resistor and the equivalent resistance of the network of five resistors.

IDENTIFY and SET UP This network is neither a series combination nor a parallel combination. Hence we must use Kirchhoff’s rules to find the values of the target variables. There are five unknown currents, but by applying the junction rule to junctions *a* and *b*, we can represent them in terms of three unknown currents I_1 , I_2 , and I_3 , as shown in Fig. 26.12.

EXECUTE We apply the loop rule to the three loops shown:

$$13 \text{ V} - I_1(1 \Omega) - (I_1 - I_3)(1 \Omega) = 0 \quad (1)$$

$$-I_2(1 \Omega) - (I_2 + I_3)(2 \Omega) + 13 \text{ V} = 0 \quad (2)$$

$$-I_1(1 \Omega) - I_3(1 \Omega) + I_2(1 \Omega) = 0 \quad (3)$$

Figure 26.12 A network circuit with several resistors.

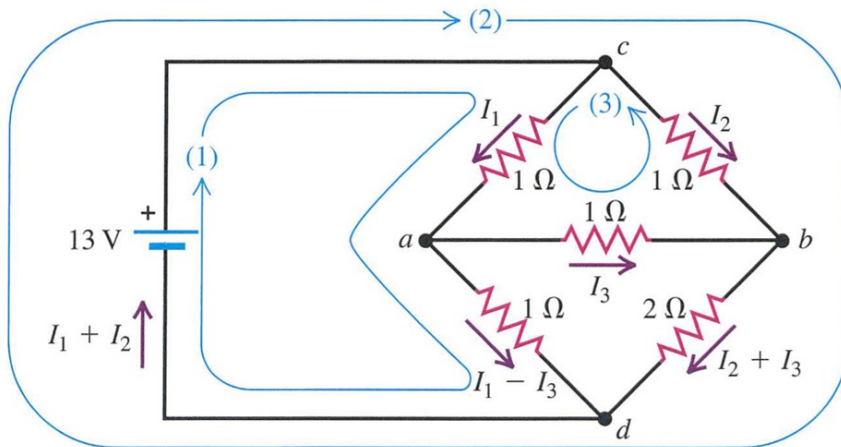

One way to solve these simultaneous equations is to solve Eq. (3) for I_2 , obtaining $I_2 = I_1 + I_3$, and then substitute this expression into Eq. (2) to eliminate I_2 . We then have

$$13 \text{ V} = I_1(2 \Omega) - I_3(1 \Omega) \quad (1')$$

$$13 \text{ V} = I_1(3 \Omega) + I_3(5 \Omega) \quad (2')$$

Now we can eliminate I_3 by multiplying Eq. (1') by 5 and adding the two equations. We obtain

$$78 \text{ V} = I_1(13 \Omega) \quad I_1 = 6 \text{ A}$$

We substitute this result into Eq. (1') to obtain $I_3 = -1 \text{ A}$, and from Eq. (3) we find $I_2 = 5 \text{ A}$. The negative value of I_3 tells us that its direction is opposite to the direction we assumed.

The total current through the network is $I_1 + I_2 = 11 \text{ A}$, and the potential drop across it is equal to the battery emf, 13 V. The equivalent resistance of the network is therefore

$$R_{\text{eq}} = \frac{13 \text{ V}}{11 \text{ A}} = 1.2 \Omega$$

EVALUATE You can check our results for I_1 , I_2 , and I_3 by substituting them back into Eqs. (1)–(3). What do you find?

KEYCONCEPT Some circuits have combinations of resistors that are neither in series nor in parallel. To analyze any such circuit, use Kirchhoff’s loop rule and junction rule.

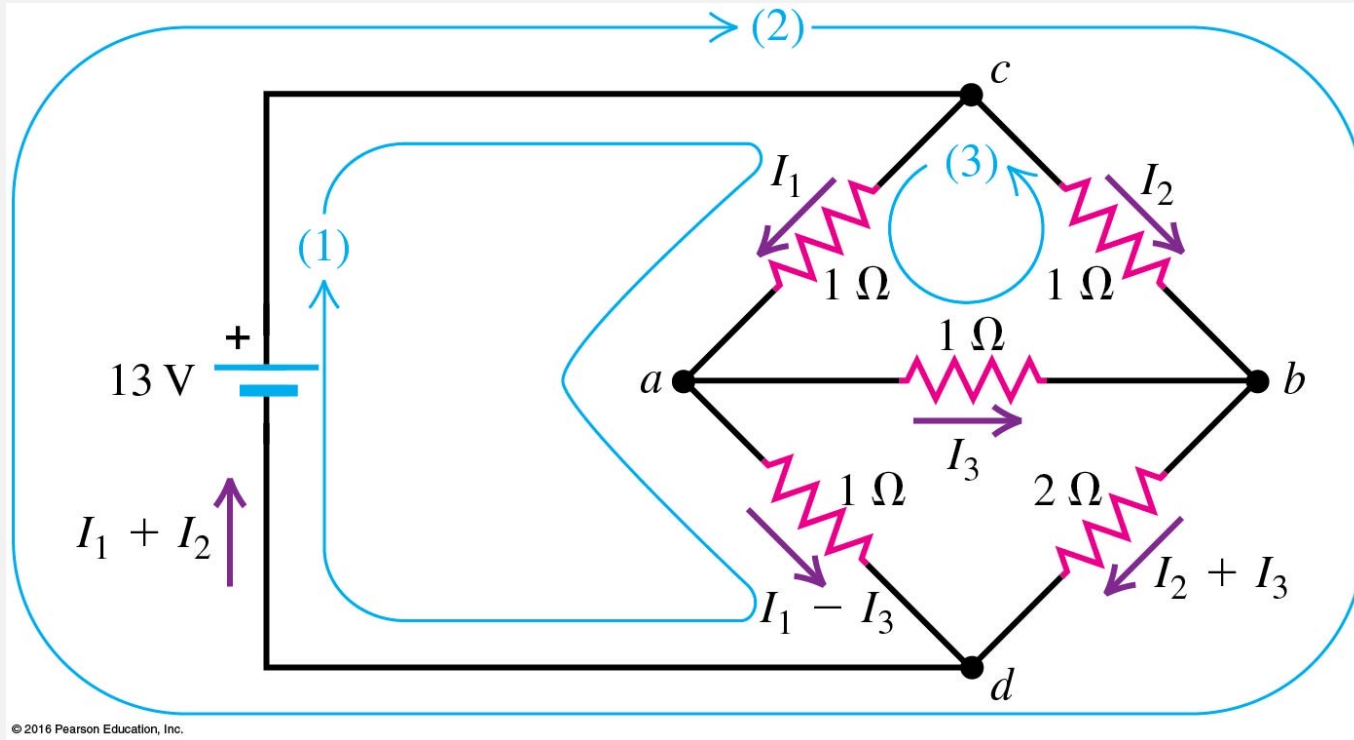

電壓計與電流計

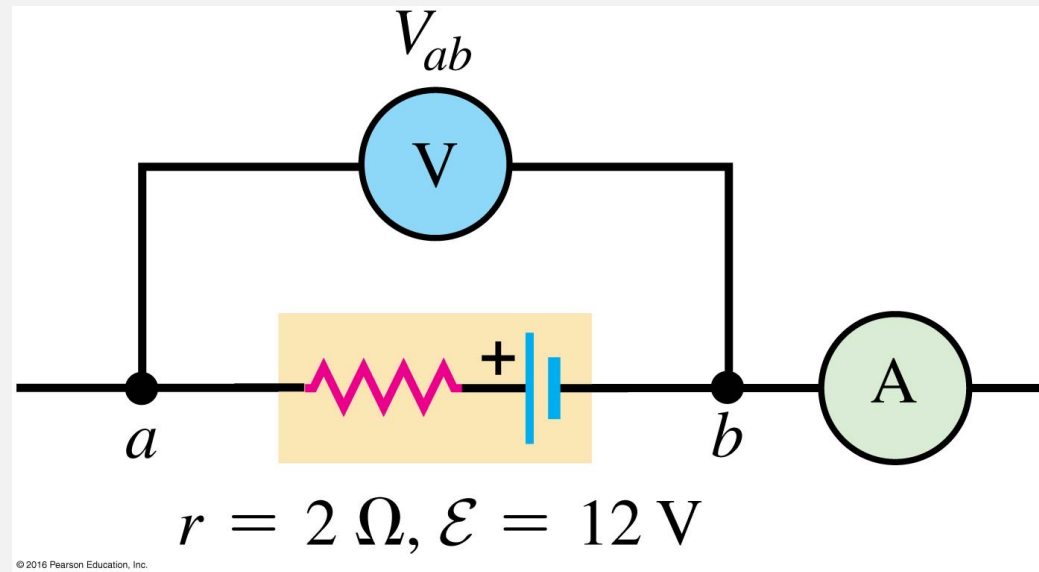

$$V_{ab} = V_{a'b'}$$

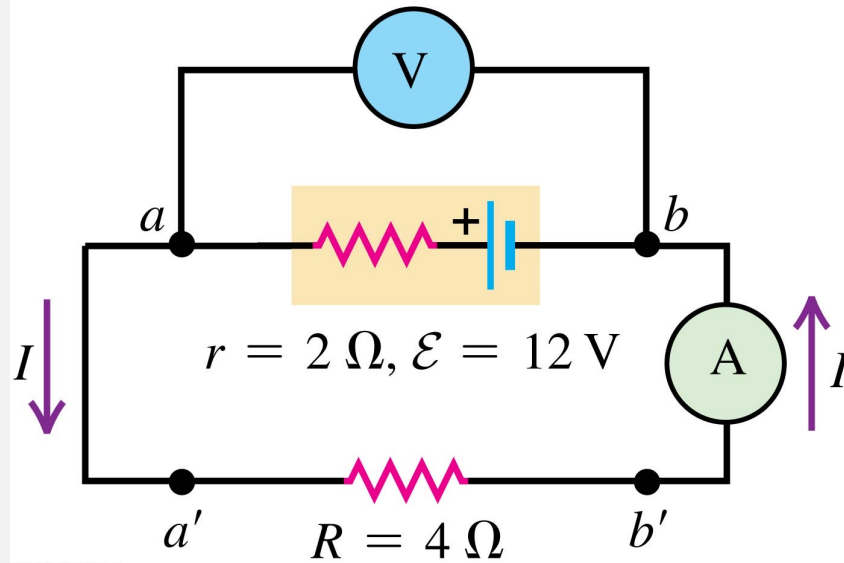

固體是原子組成的晶格 Lattice

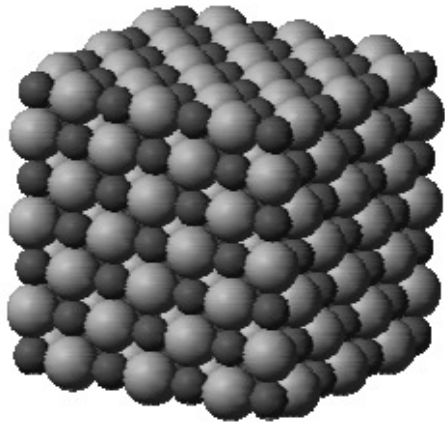
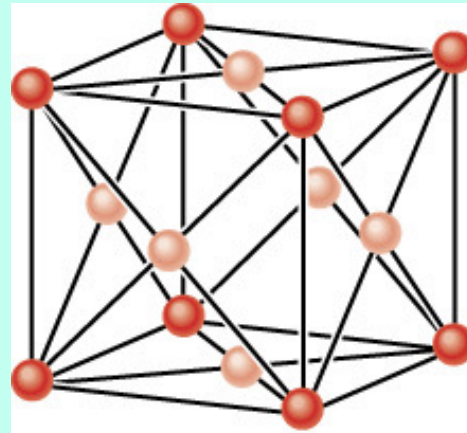

Fig. 7.1: **Left:** Small units reproduced periodically to form a crystal. This particular figure depicts NaCl (table salt), with the larger spheres being Cl^- ions and the smaller spheres being Na^+ ions. **Right:** The macroscopic morphology of a crystal often will reflect the underlying microscopic structure. These are large crystals of salt (also known as halite). Photograph by Piotr Włodarczyk, used by kind permission.

導體內為何會有電荷可以流動？

電子不是束縛在原子核旁邊嗎？

絕緣體內為何就沒有電荷可以流動呢？



Copper fcc

(a)

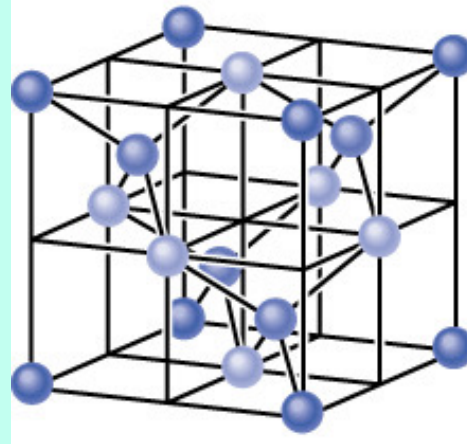

Silicon and Carbon

Thomson發現原子可以分割為更加細微的一種物質基本組成成分，此成分只有一種，此一種成分組成了所有的不同的原子！這比化學的原子論又跨進了一大步！

電子 Electron

e^-

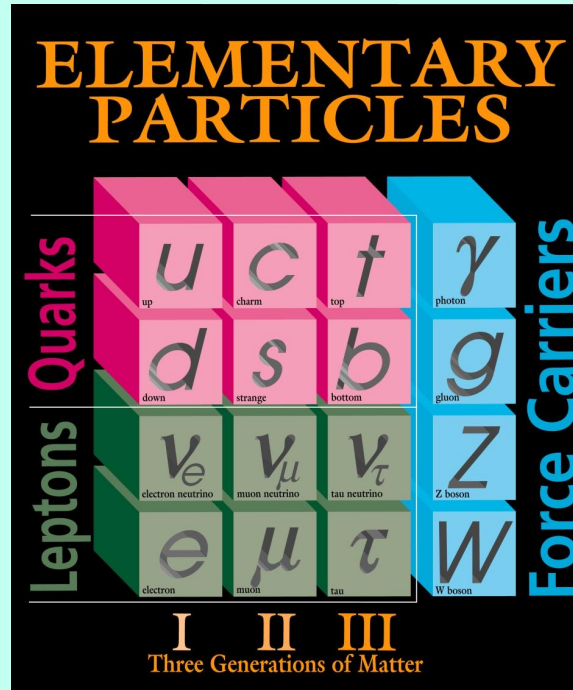

The PARTICLE ZOO
Handmade Subatomic Particle Plushies FROM THE STANDARD MODEL OF PHYSICS & beyond!
{ ages 5 and up }

Available on the App Store

QUARKS	UP QUARK A teeny little point inside the proton and neutron, it is friends forever with the down quark.	CHARM QUARK A second generation quark, he is charmed, indeed.	TOP QUARK This heavyweight champion doesn't live long enough to make friends with anyone.	COSMIC MICROWAVE BACKGROUND RADIATION plushie
	DOWN QUARK A tiny little point inside the proton and neutron, it is friends forever with the up quark.	STRANGE QUARK What's so strange about this second generation quark?	BOTTOM QUARK This third generation quark is puttin' on the powers.	PHOTON The massless warlike we know and love.
LEPTONS	ELECTRON-NEUTRINO This miniscule bandit is so light, he is practically massless.	MUON-NEUTRINO Like the other 2 neutrinos, he's got an identity crisis from oscillation.	TAU-NEUTRINO He's a fast one, but what type of neutrino will he be next?	GLUON The "glue" of the strong nuclear force.
	ELECTRON A familiar friend, this negatively charged, busy fella likes to bond.	MUON A "heavy electron" who lives fast and dies young.	TAU A "heavy muon" who could stand to lose a little weight.	

Internet Explorer Microsoft PowerPo... 貴州點金壹環球通

原子內的正電與大部分的質量集中於極小的**原子核 Nucleus**

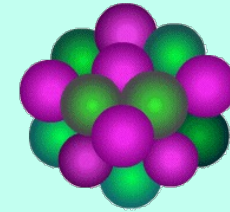
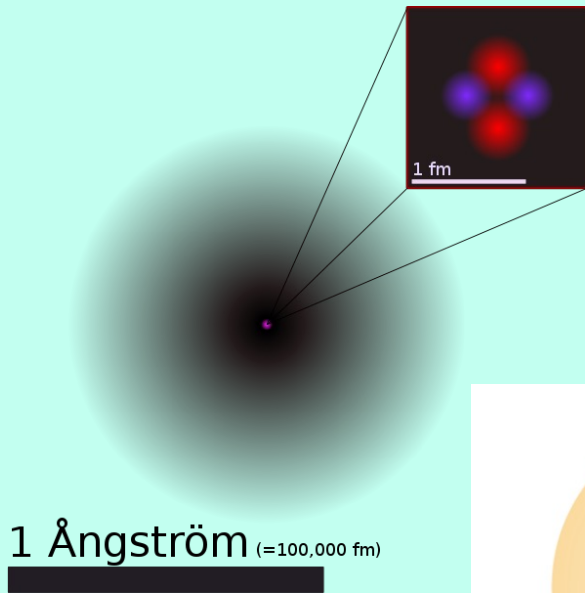

Nucleus

10^{-15} m

10^{-10} m

If an atom could be expanded to the size of a football stadium, the nucleus would be the size of a single blueberry. (credit middle: modification of work by "babyknight"/Wikimedia Commons; credit right: modification of work by Paxson Woelber)



電子在一個很重的帶正電的原子核旁如何維持穩定狀態？

電子可以繞著原子核轉動：

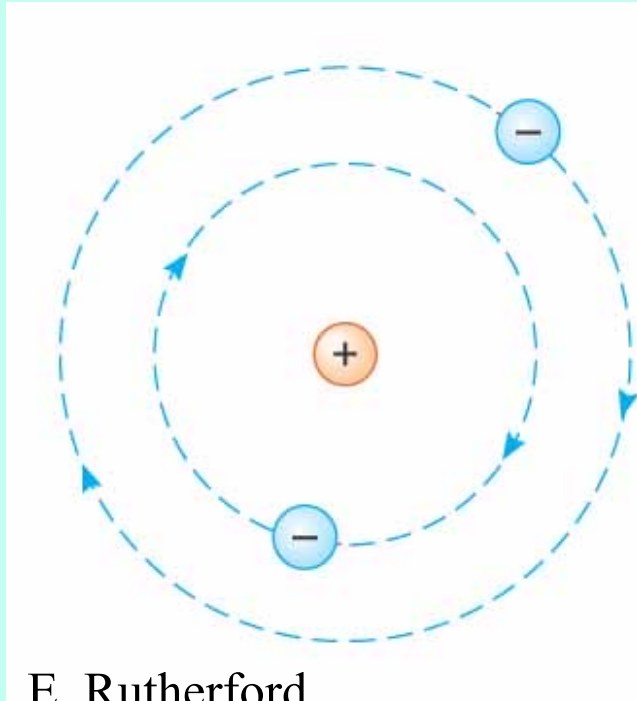

E. Rutherford

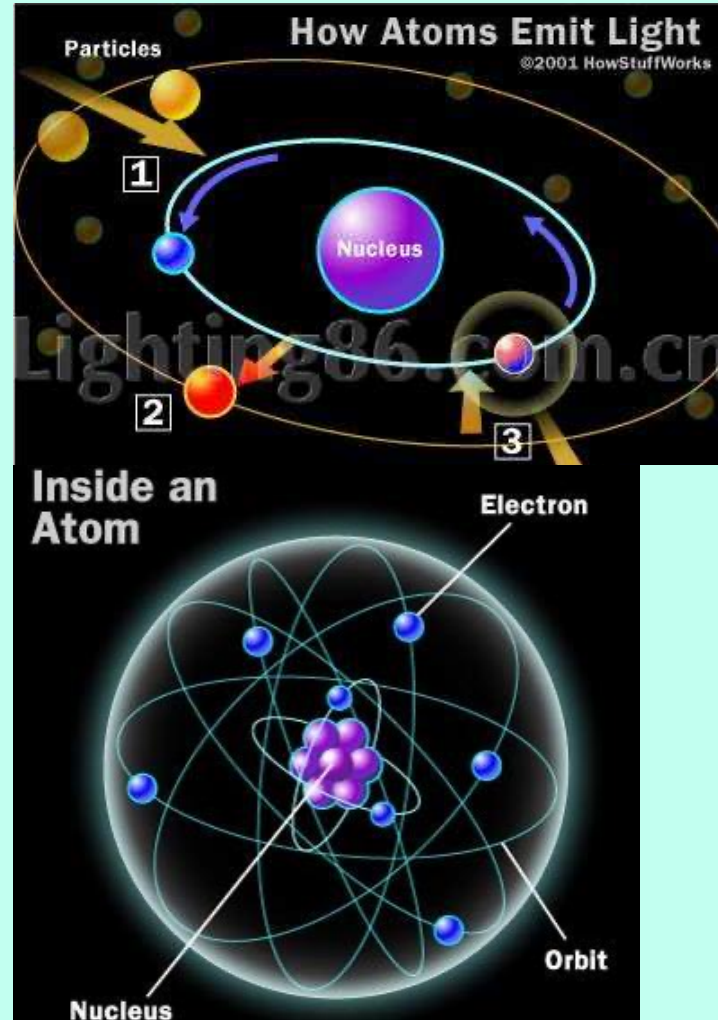
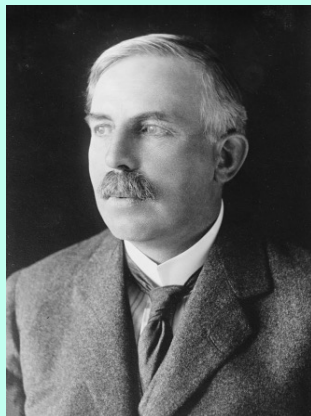

But, this is not right!

加速的電荷會發出對應頻率的電磁波，也就是光!

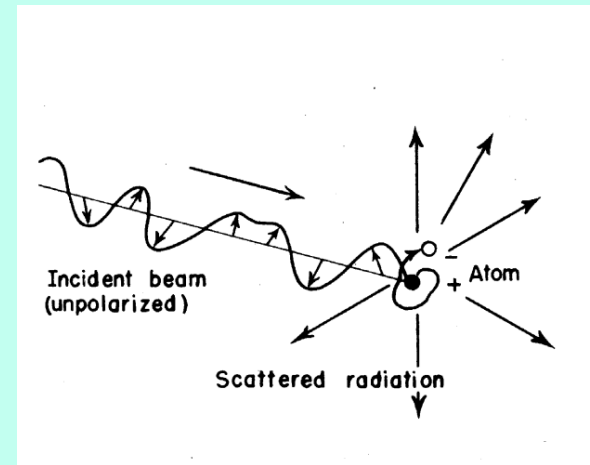
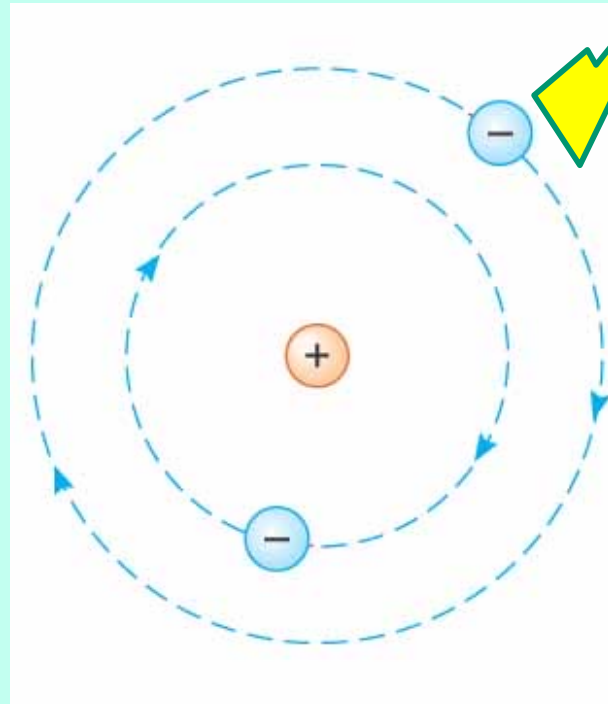

光帶走能量！

電子很快就會跌入原子核之中！

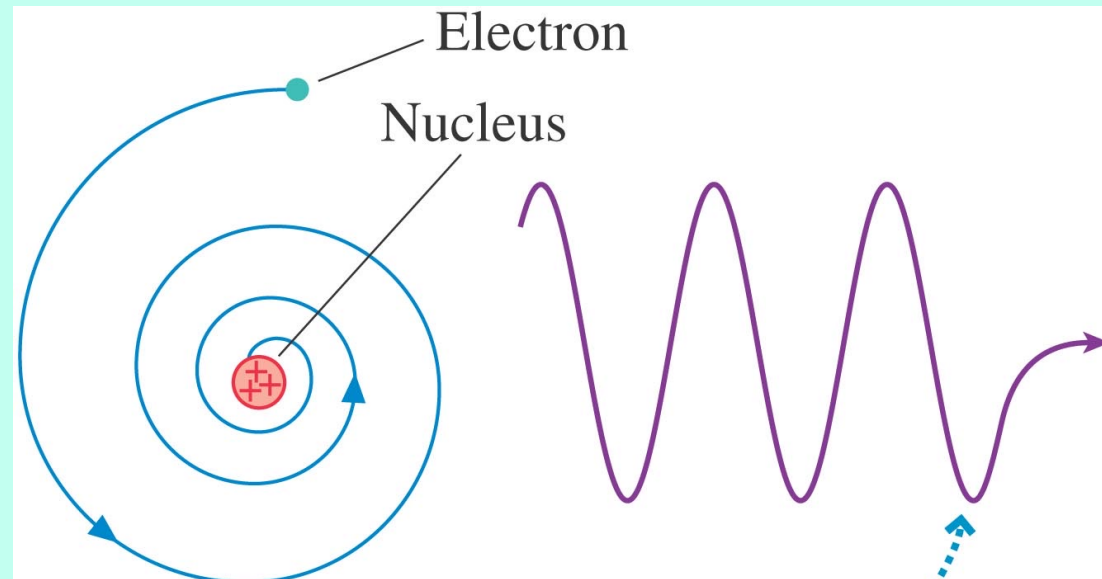

這個太陽系般的原子模型並不穩定！

原子的結構有大問題。

波爾原子模型的基本假設

原子中電子的狀態是一系列**分離的穩定態** **Stationary States**。

穩定態的能量 E_n ，以一個自然數 n 標定， n 稱為量子數！

$$E_n \propto -\frac{1}{n^2}$$

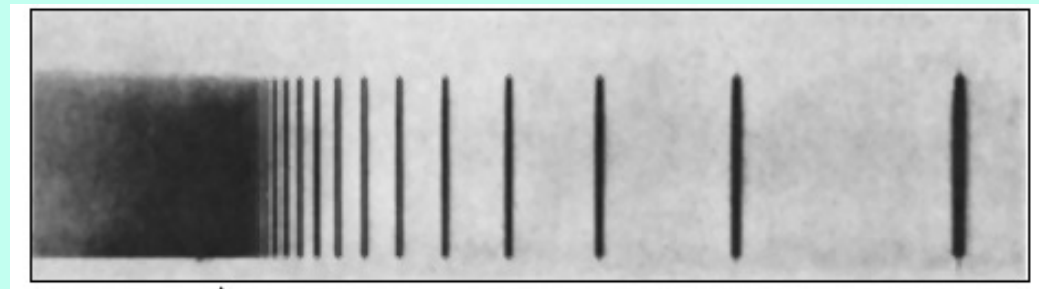
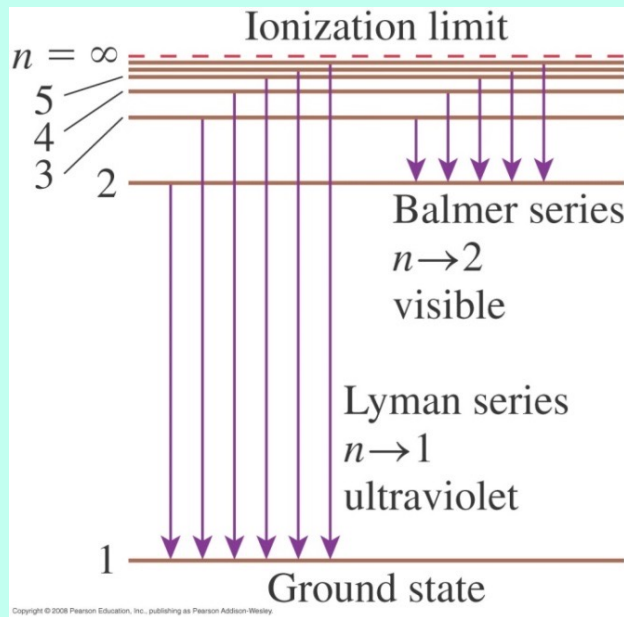

電子在能態間**躍遷**，同時放出或吸收一個**光子**，光子的能量即能態的能量差：

因為穩定態是離散分布，所以發出的光子頻率不是連續的。

但更要緊的是：假設電子是波的好處是甚麼？

將原子中的電子波放在有限的圓形軌道上，波函數在圓周上必須一致，
圓周必須是波長的整數倍值，因此電子的軌道不能任意！

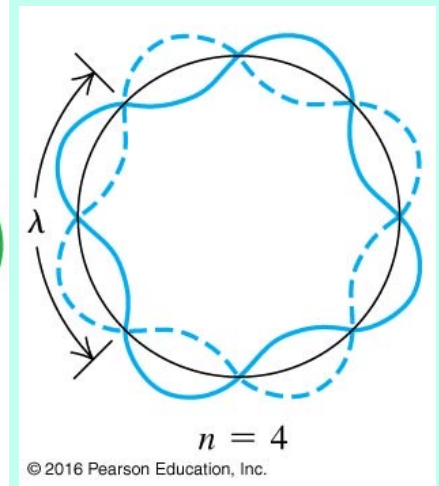
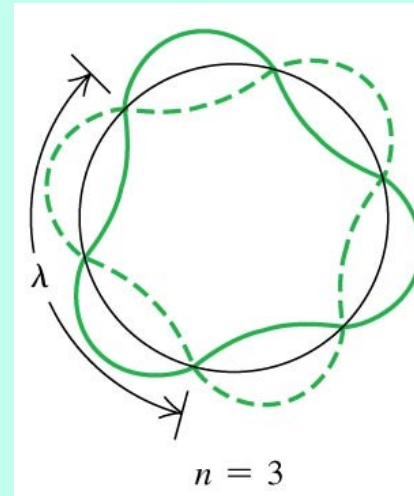
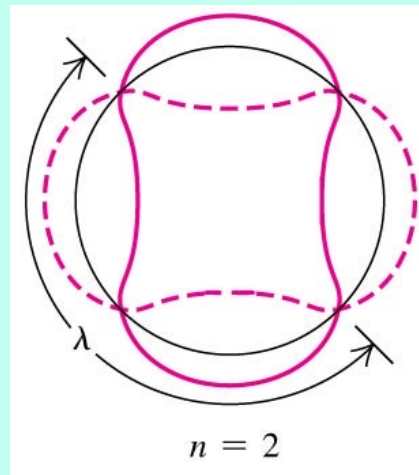
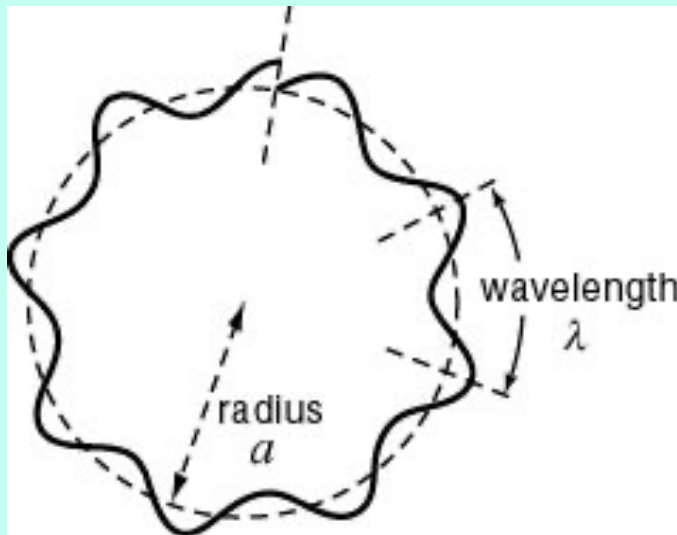

$$\frac{2\pi r}{\lambda} = n$$

週期性條件

$$\frac{h}{\lambda} \cdot r = n \frac{h}{2\pi}$$

$$p \cdot r = L = n\hbar$$

波爾的量子化條件

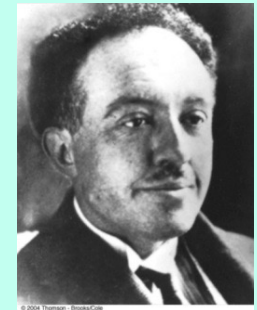

軌道的量子化可以由物質波的週期性條件推導出來！

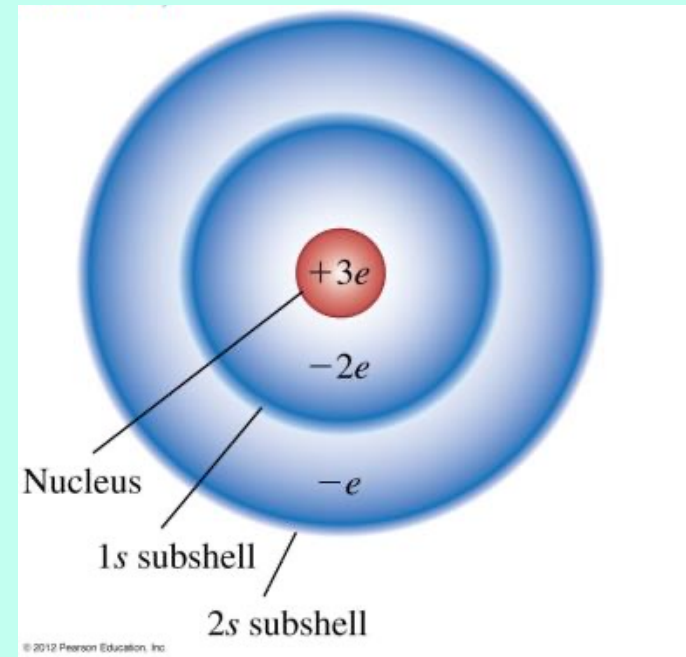
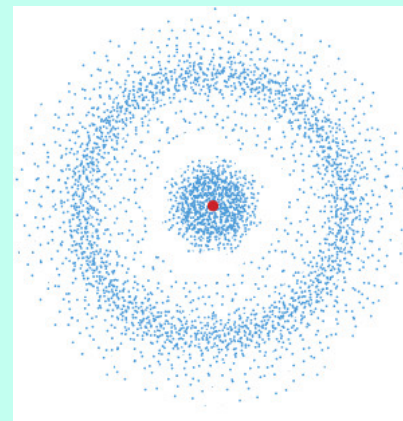
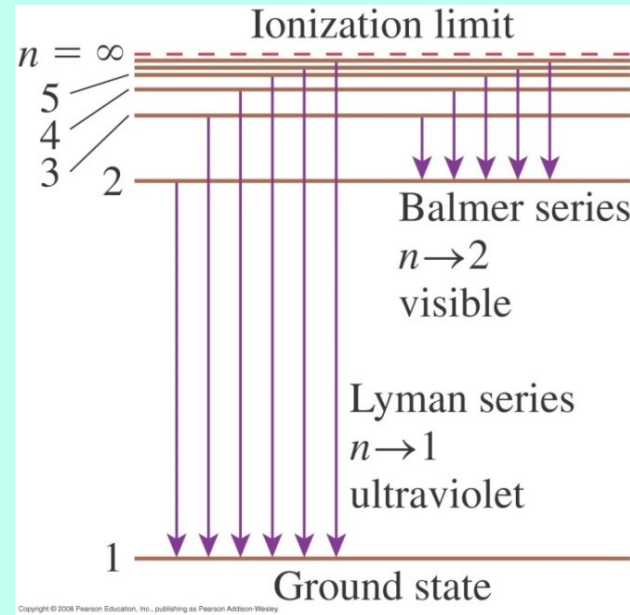
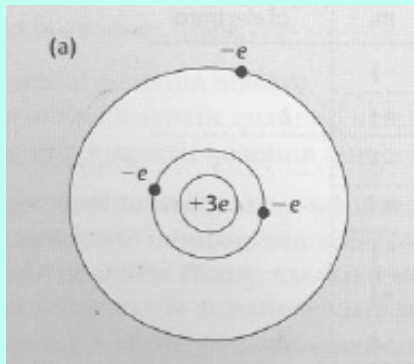

$$\frac{\partial^2 \psi_E}{\partial x^2} + \frac{\partial^2 \psi_E}{\partial y^2} + \frac{\partial^2 \psi_E}{\partial z^2} = \frac{2m}{\hbar^2} \left[\frac{-ke^2}{r} - E \right] \psi_E$$

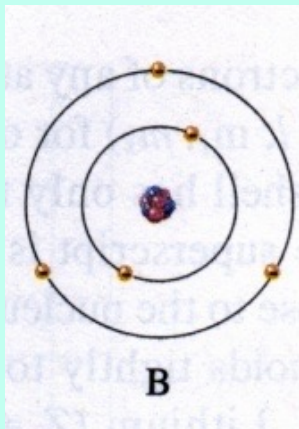
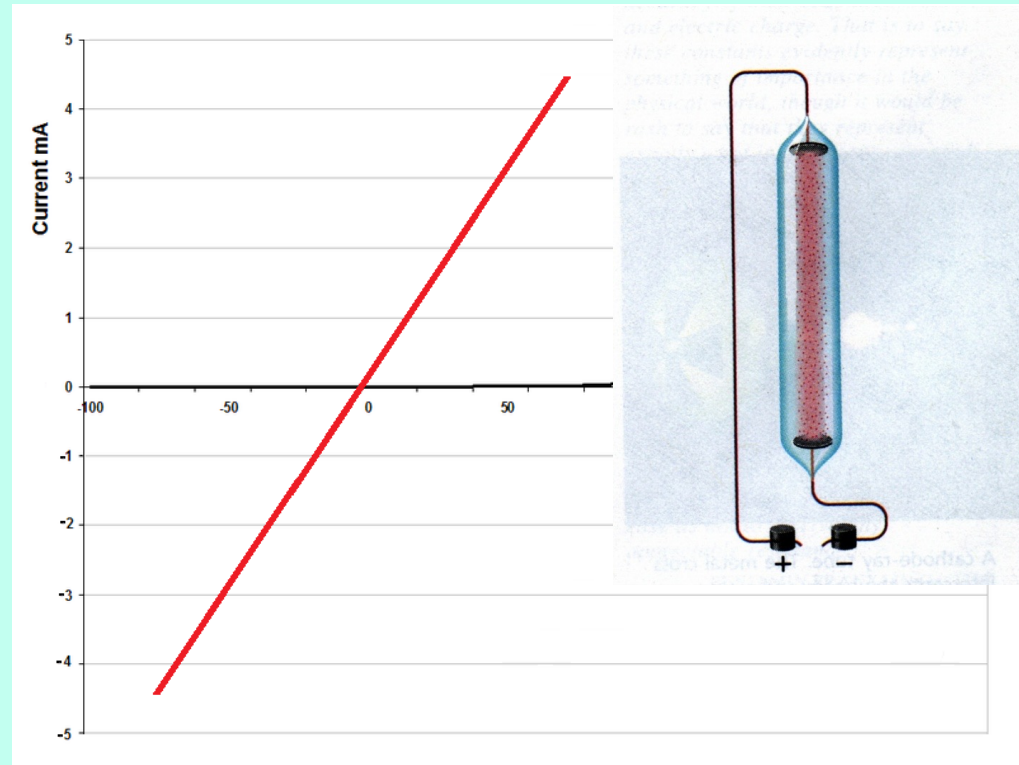
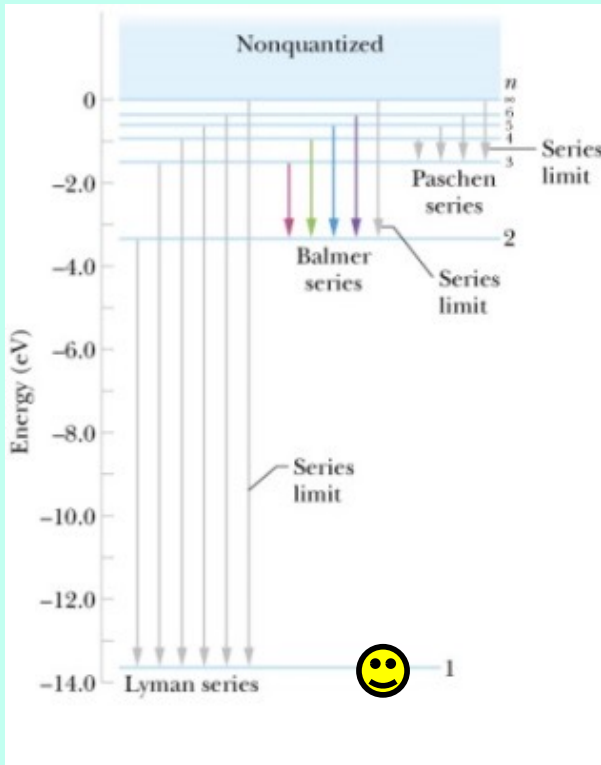

在原子中，電子被束縛在原子核旁邊。能量呈現能階的形式。要讓原來處於基態的電子離開原子核，至少需要13伏特的電壓。這對氣態的原子的確是對的！稱為氣體放電。但在固態導體中，顯然很小的電壓就能產生電流。歐姆定律。導體內為何有機動的mobile電荷可以自由流動？絕緣體內為何又沒有電荷可以流動呢？

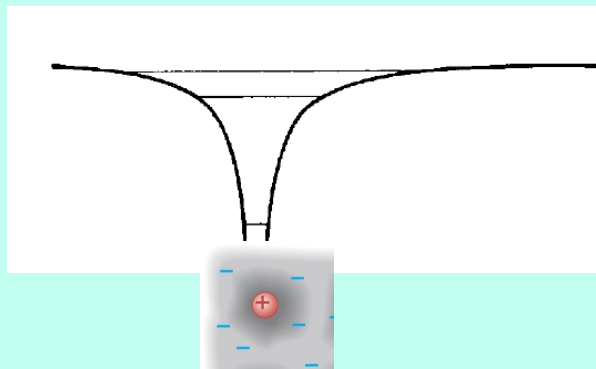

在獨立的原子中，位能為庫倫位能，電子的能態形成分離的能階。
當原子彼此靠近時，多個原子核的庫倫位能都必須考慮，
也就是，電子會同時感覺多個原子核的電力。

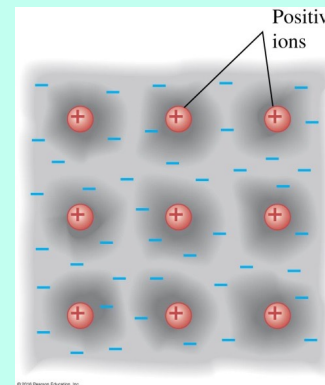
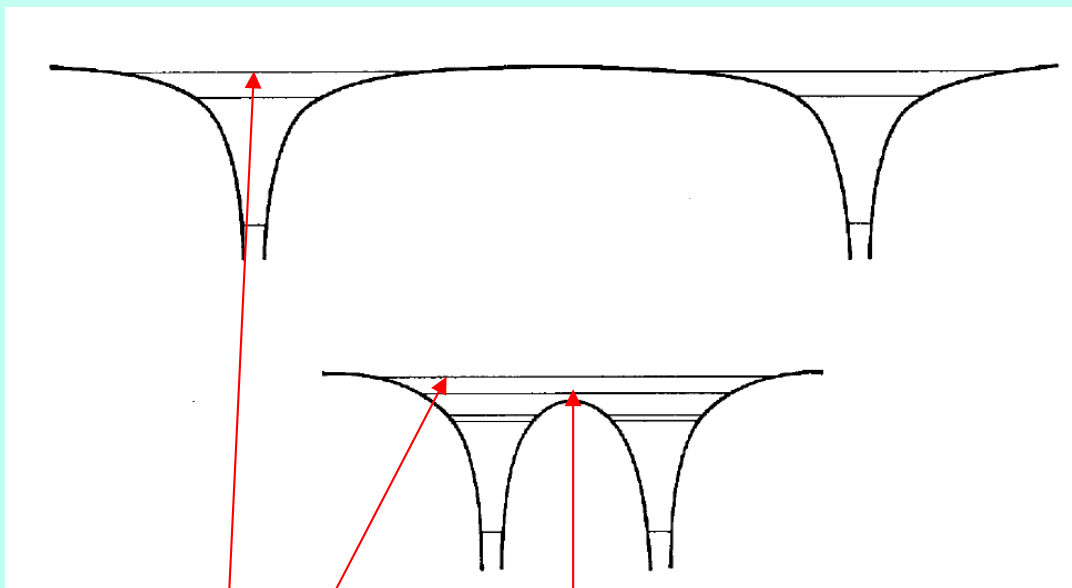

原子間的庫倫電位能疊加後會下降，
能量比較高的能態，就可能跨越原子間的位能。

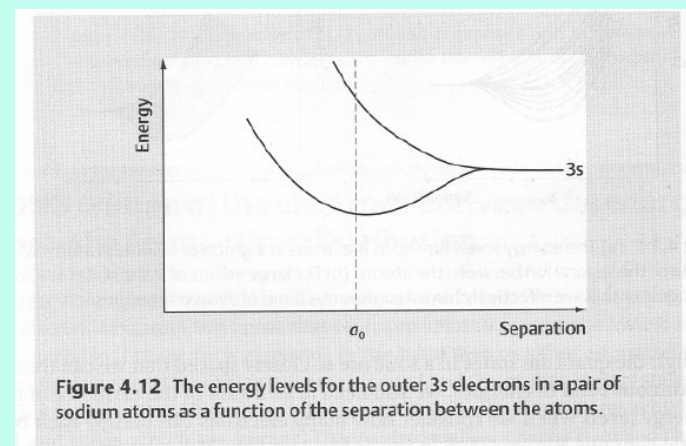
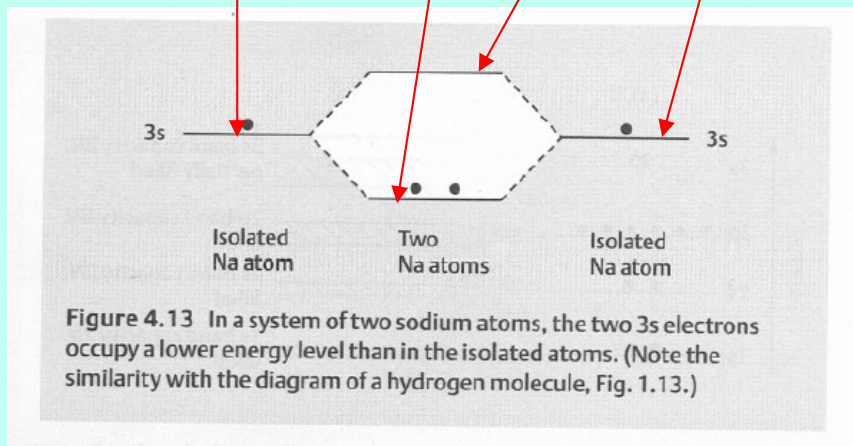
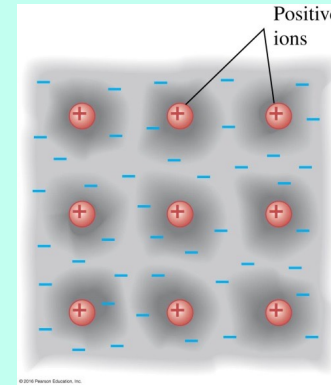
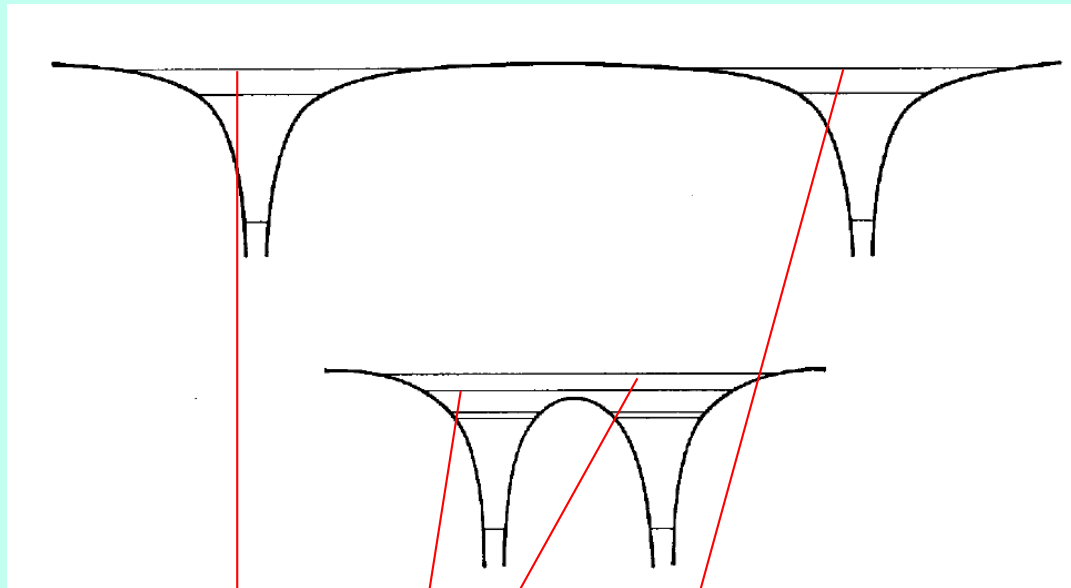

跨越原子間的位能後，
 這兩個來自兩個原子，但原本能量相同的能態會彼此混合，
 然後分裂為兩個能量相近的能態。
 能量差會隨距離靠近而增加、但相對小於原來能階能量差。

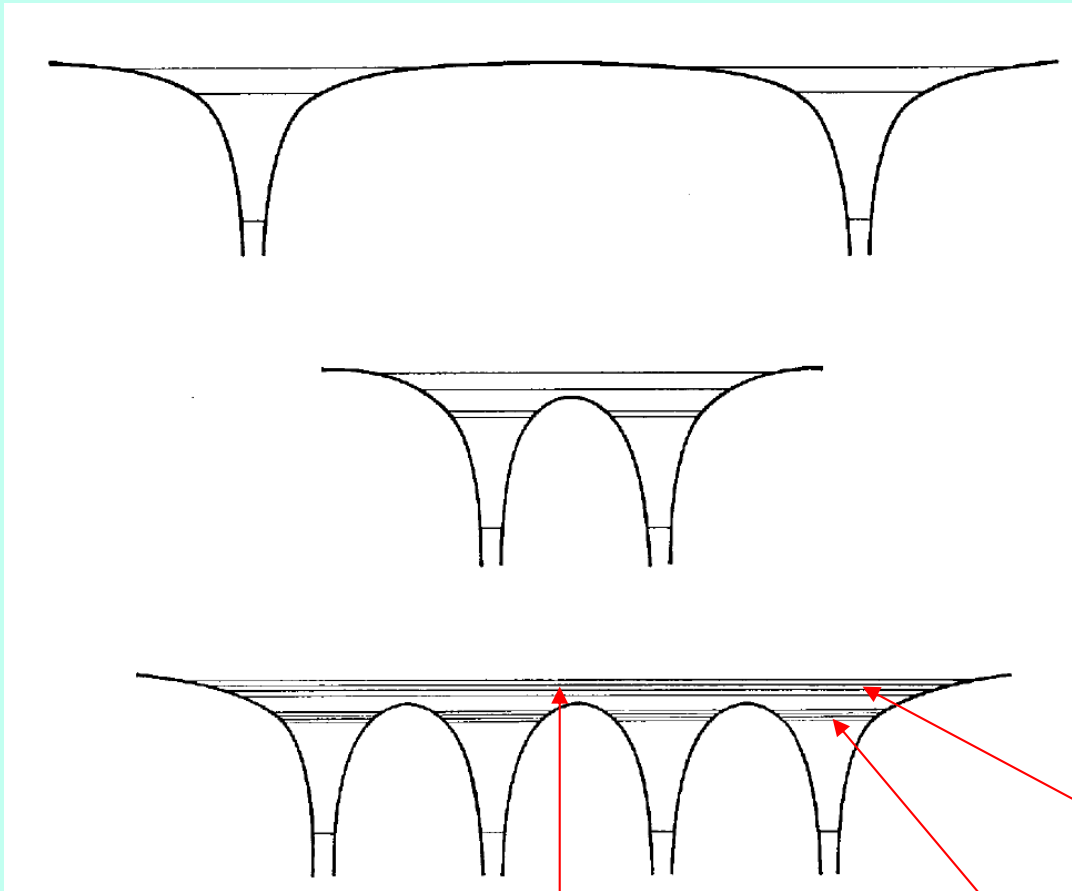

如果有多個原子，就會有多個能量相同的能態，跨越原子間的位能。
同樣的推導也適用，因此就會有多個能量相近、但稍有能量差的的能態。
這些原來屬於私人的電子現在是**公共財產**！其餘電子還是束縛在單一原子內。
這樣的電子會受到所有的原子的影響！他們的波函數會分布於所有原子間。
這樣的電子波滿足：在週期性晶格位能下的薛丁格方程式。

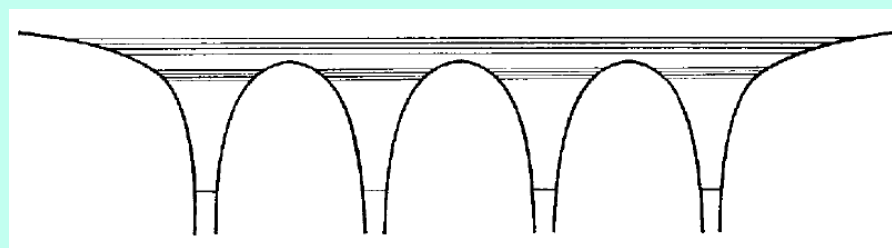

這些跨越原子間的能態，原來是來自能量相等的、束縛於單一原子中的能態，因此能態總數等於原子數目，數量龐大！

當原子距離縮小後，它們的能量會彼此出現些微差距，差距隨距離縮小而變大。

大量能階擠入微小的能量差距，這些能階就形成了幾乎連續的能帶 **Energy Band**！

在計算時，將距離取為真實的原子間距，就得到真實的電子能態所形成的能帶。

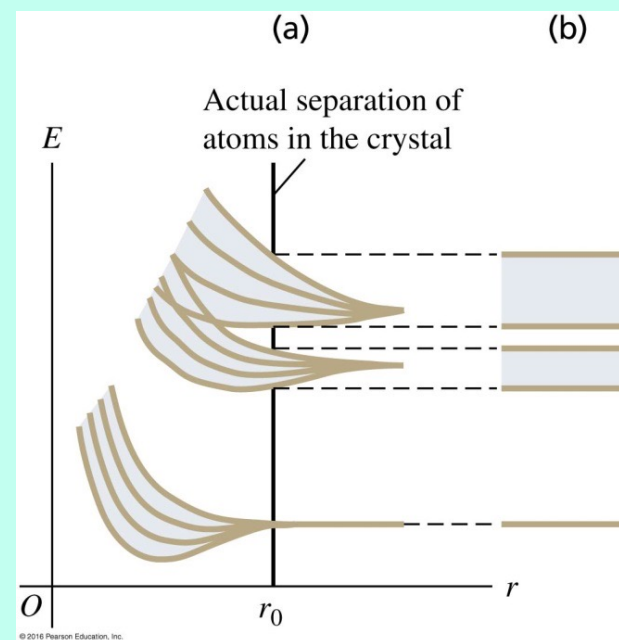
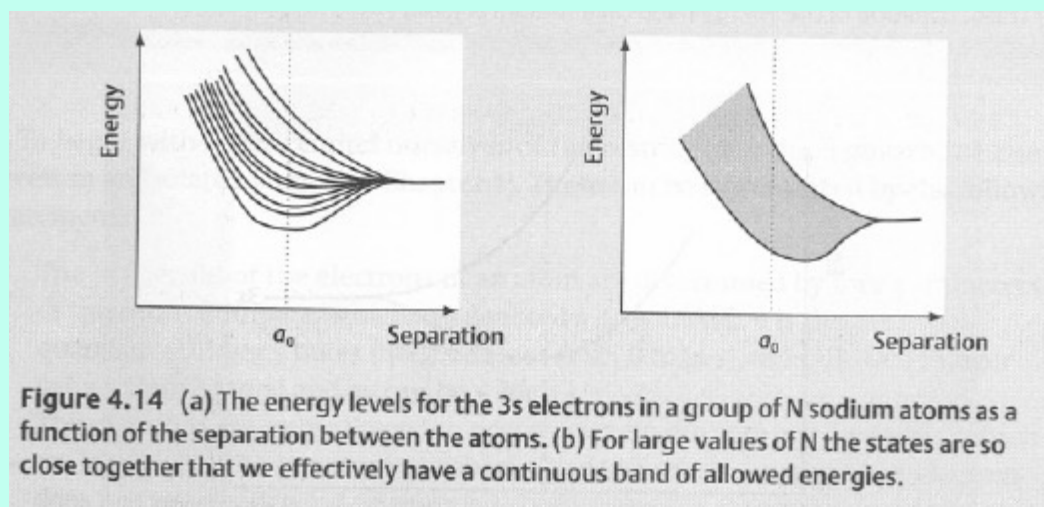

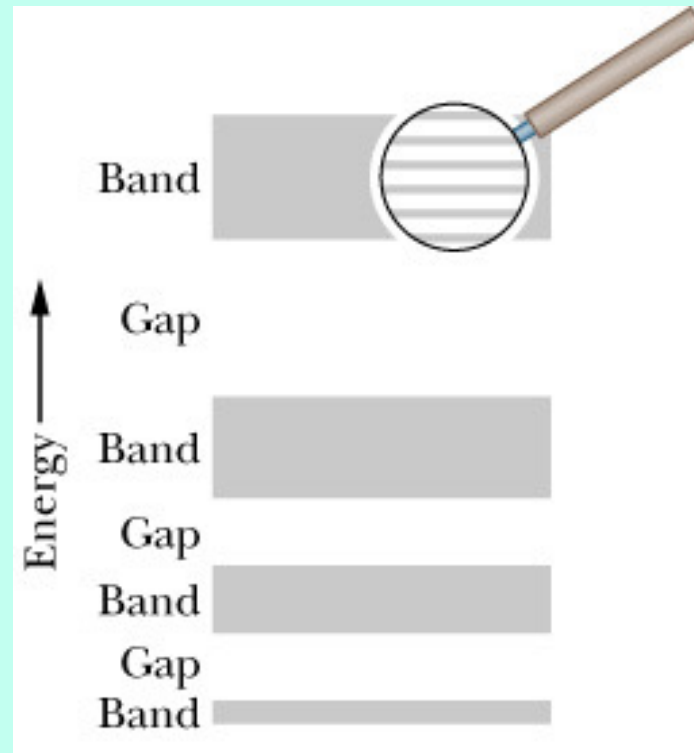
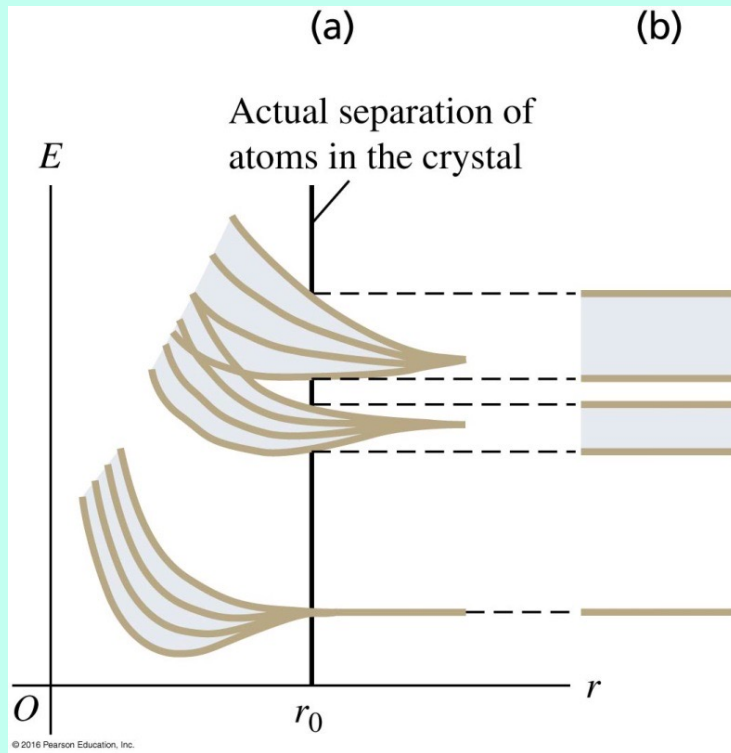

所以固體中的電子能態(能量本徵值)，形成一個個能帶，能帶之間可能有間隙！

固態物理之父Bloch



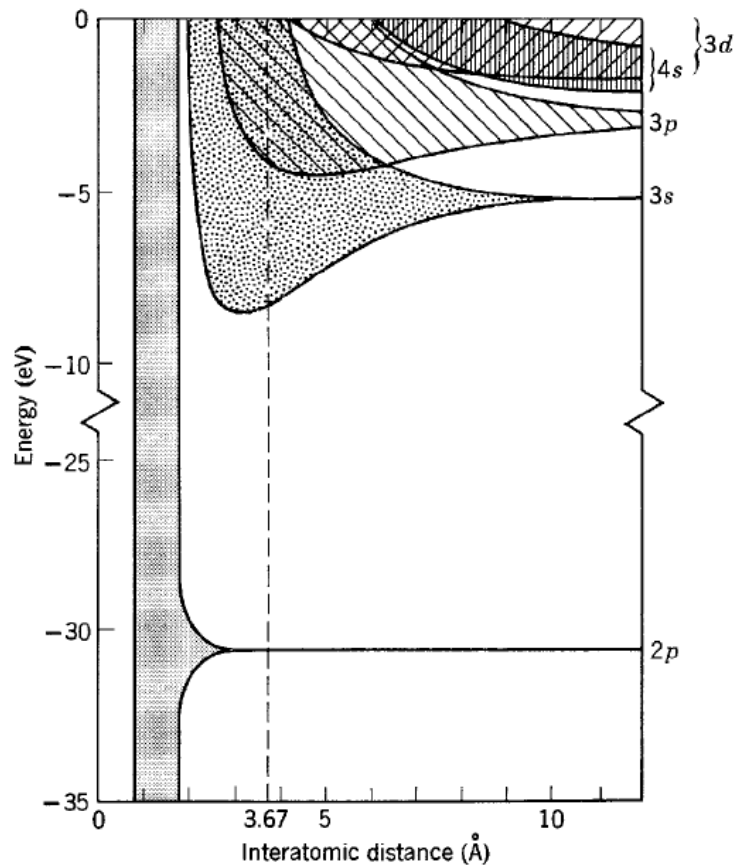

Figure 13-3 Showing the formation of energy bands from the energy levels of isolated sodium atoms as the interatomic separation decreases. The dashed line indicates the observed interatomic separation in solid sodium. The several overlapping bands that constitute each *p* or *d* band are not indicated.

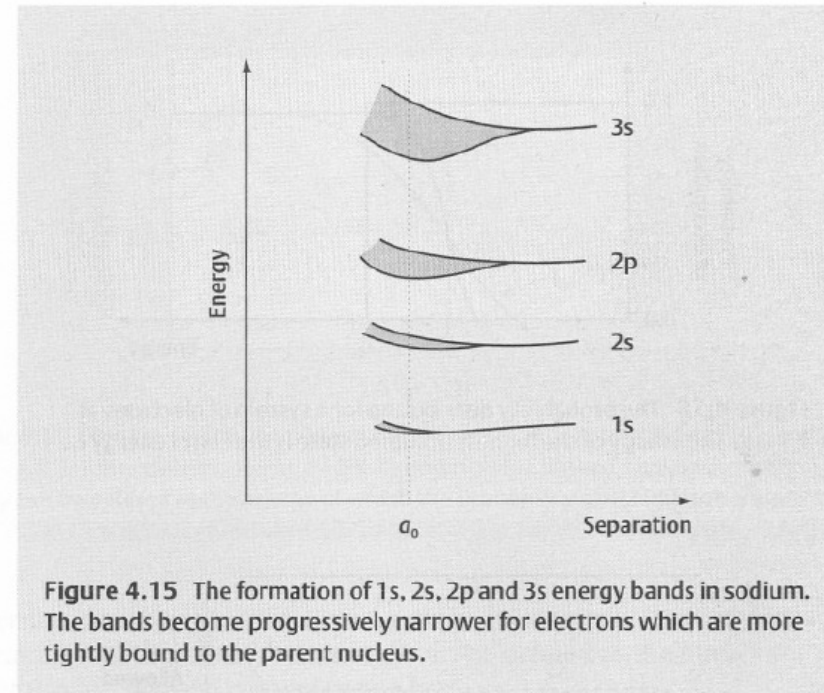

Figure 4.15 The formation of 1s, 2s, 2p and 3s energy bands in sodium. The bands become progressively narrower for electrons which are more tightly bound to the parent nucleus.

這是鈉的能帶。

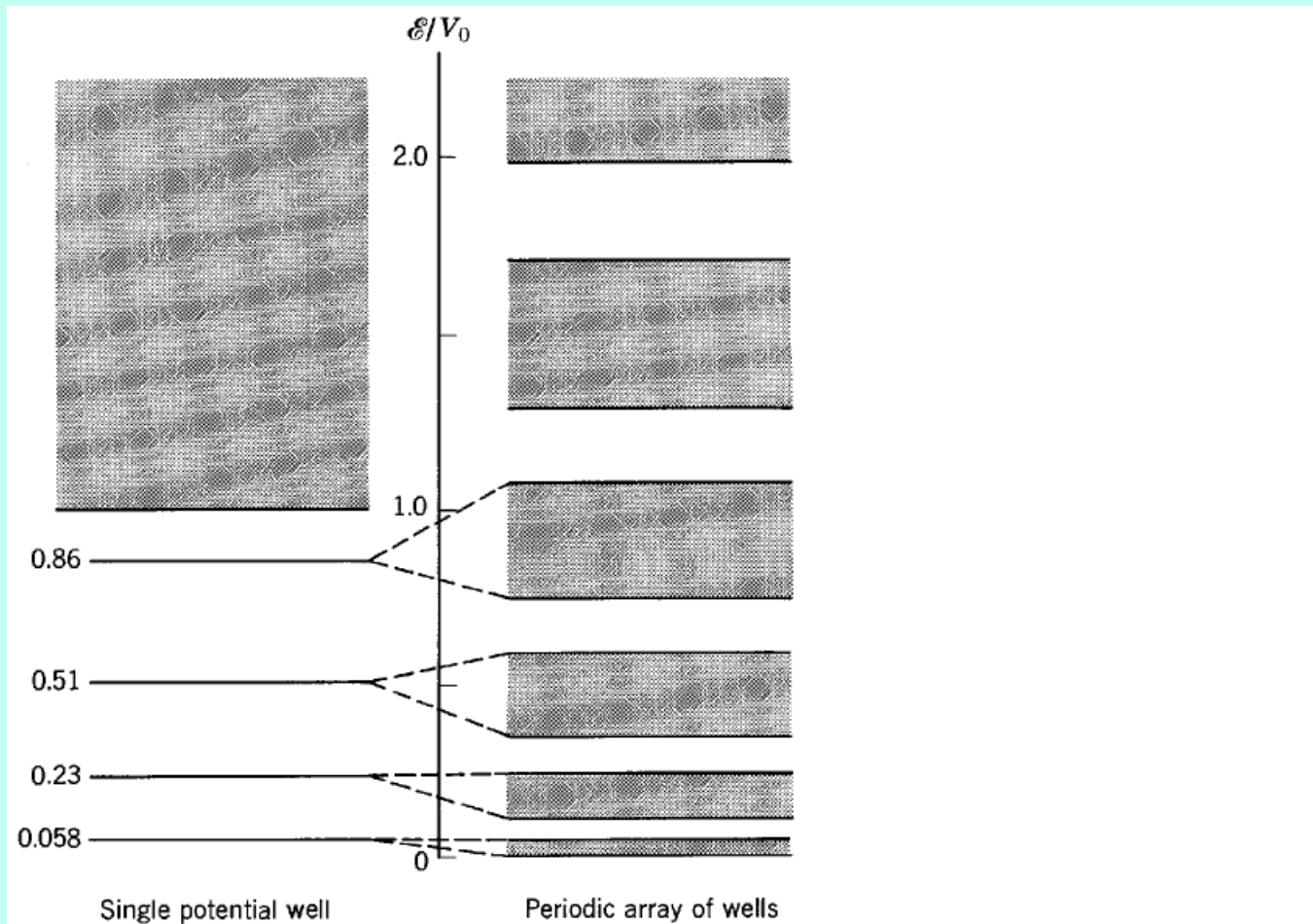
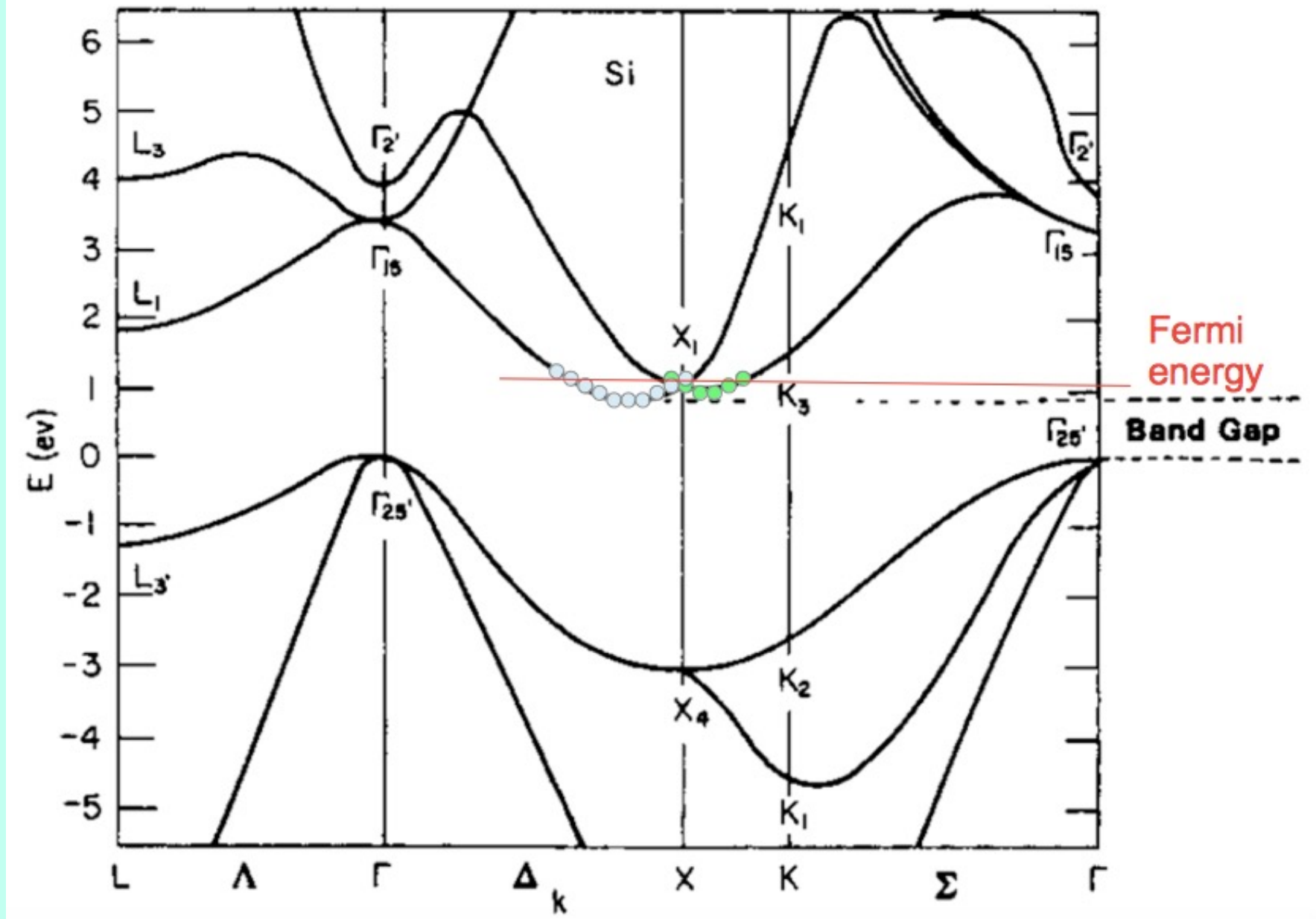

Figure 13-9 *Left:* Allowed energies for an electron in a single potential well. *Right:* Allowed energies in an array of periodically spaced wells and barriers. The levels shown are for a well strength given by $2mV_0l^2/\hbar^2 = (11)^2$, and a barrier thickness $b = l/16$. Note the appearance of forbidden bands even for energies ϵ greater than V_0 .



橫軸是能態波函數的空間變化率，與動量有關。

原子中的電子，會一個一個由下往上填。電子就由最低的能階向上一一配置！

Pauli 不相容原理：兩個電子不能占據同一個量子態。

同一個軌道量子態，最多只能放置兩個電子，自旋向上及向下。

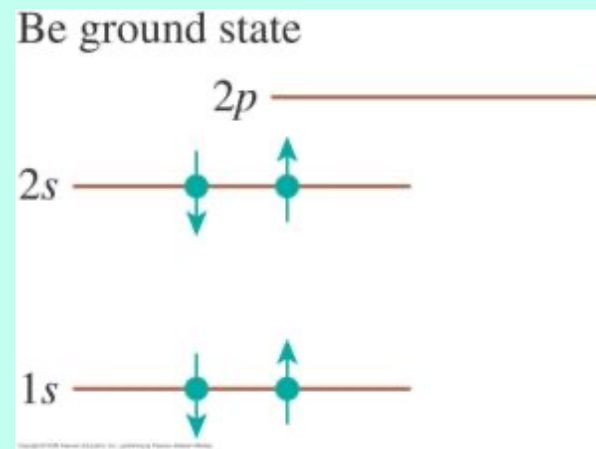
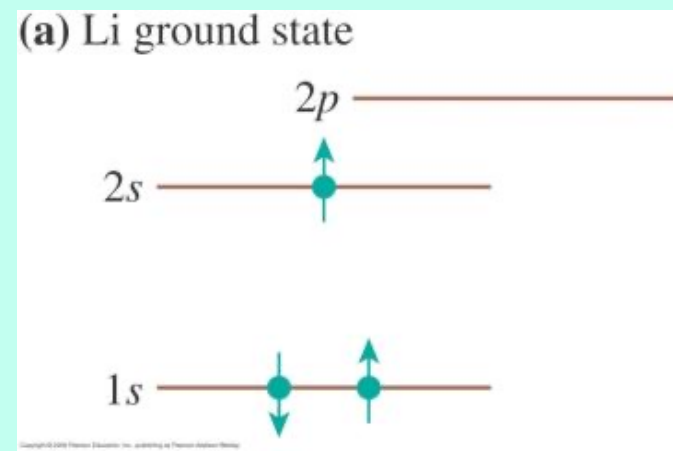
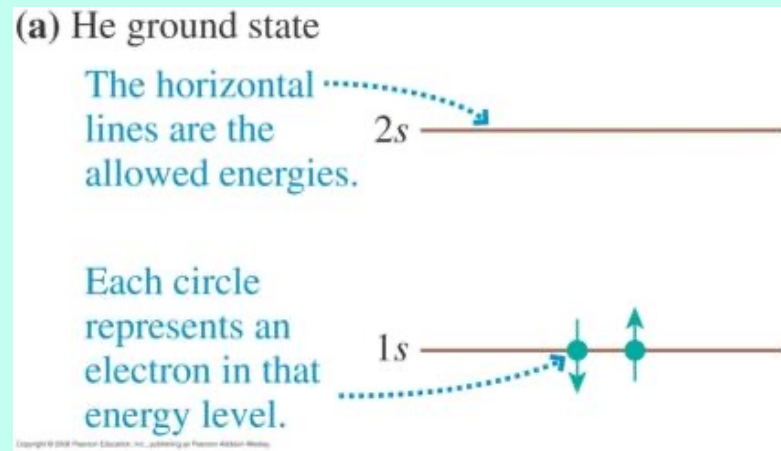

原子中的電子，會一個一個由下往上填。

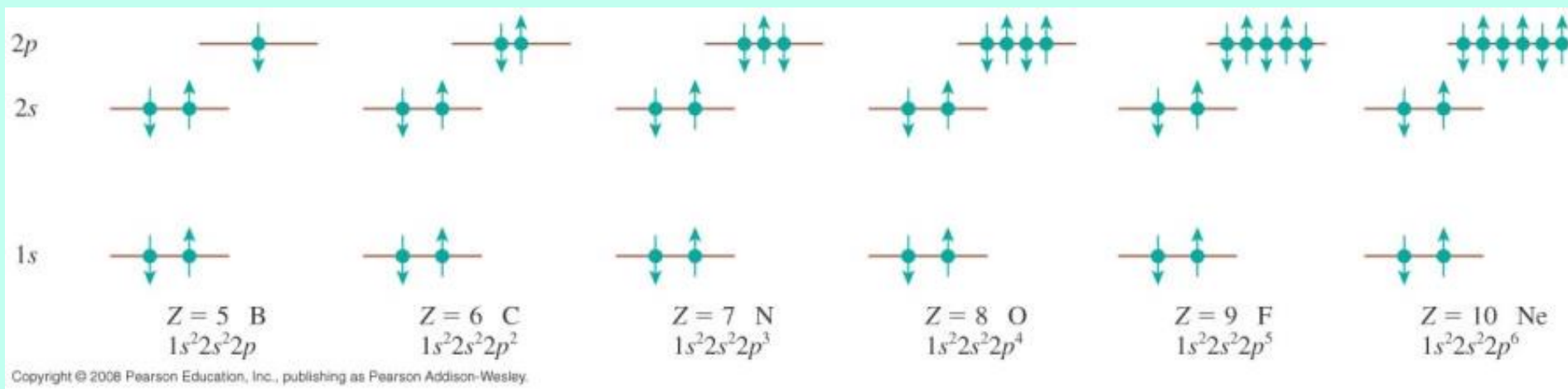

Period 1	1																	2
	H																	He
2	3	4											5	6	7	8	9	10
	Li	Be	Transition elements										B	C	N	O	F	Ne
3	11	12											13	14	15	16	17	18
	Na	Mg											Al	Si	P	S	Cl	Ar
4	19	20	21	22	23	24	25	26	27	28	29	30	31	32	33	34	35	36
	K	Ca	Sc	Ti	V	Cr	Mn	Fe	Co	Ni	Cu	Zn	Ga	Ge	As	Se	Br	Kr
5	37	38	39	40	41	42	43	44	45	46	47	48	49	50	51	52	53	54
	Rb	Sr	Y	Zr	Nb	Mo	Tc	Ru	Rh	Pd	Ag	Cd	In	Sn	Sb	Te	I	Xe
6	55	56	57	72	73	74	75	76	77	78	79	80	81	82	83	84	85	86
	Cs	Ba	La	Hf	Ta	W	Re	Os	Ir	Pt	Au	Hg	Tl	Pb	Bi	Po	At	Rn
7	87	88	89	104	105	106	107	108	109	110	111	112						
	Fr	Ra	Ac	Rf	Db	Sg	Bh	Hs	Mt	Ds	Rg							
Lanthanides 6	58	59	60	61	62	63	64	65	66	67	68	69	70	71				
	Ce	Pr	Nd	Pm	Sm	Eu	Gd	Tb	Dy	Ho	Er	Tm	Yb	Lu				
Actinides 7	90	91	92	93	94	95	96	97	98	99	100	101	102	103				
	Th	Pa	U	Np	Pu	Am	Cm	Bk	Cf	Es	Fm	Md	No	Lr				
															Inner transition elements			

Copyright © 2008 Pearson Education, Inc., publishing as Pearson Addison-Wesley.

原子中的電子，會一個一個由下往上填。

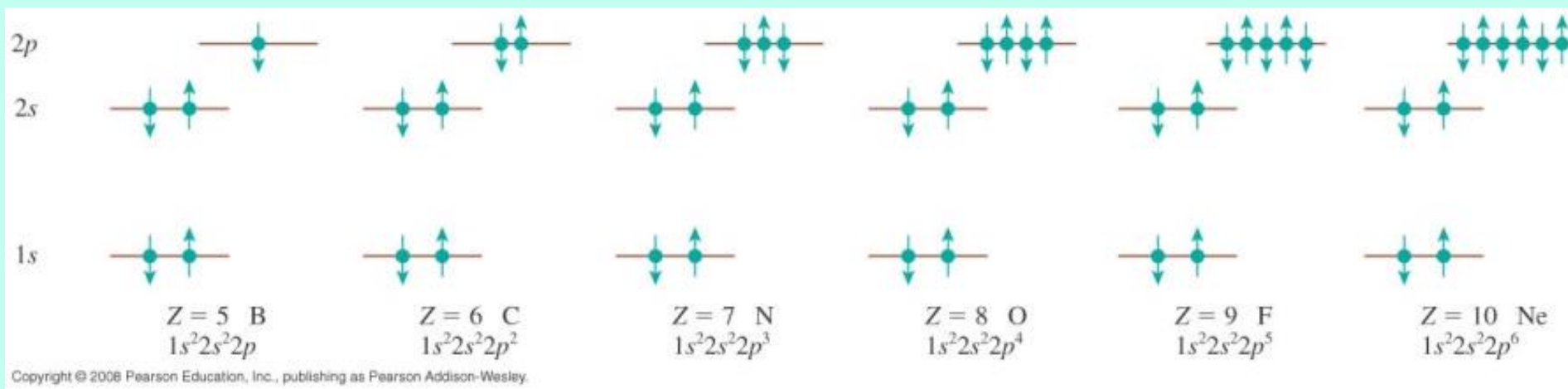

Period 1	1																	2
	H																	He
2	3	4											5	6	7	8	9	10
	Li	Be	Transition elements										B	C	N	O	F	Ne
3	11	12											13	14	15	16	17	18
	Na	Mg											Al	Si	P	S	Cl	Ar
4	19	20	21	22	23	24	25	26	27	28	29	30	31	32	33	34	35	36
	K	Ca	Sc	Ti	V	Cr	Mn	Fe	Co	Ni	Cu	Zn	Ga	Ge	As	Se	Br	Kr
5	37	38	39	40	41	42	43	44	45	46	47	48	49	50	51	52	53	54
	Rb	Sr	Y	Zr	Nb	Mo	Tc	Ru	Rh	Pd	Ag	Cd	In	Sn	Sb	Te	I	Xe
6	55	56	57	72	73	74	75	76	77	78	79	80	81	82	83	84	85	86
	Cs	Ba	La	Hf	Ta	W	Re	Os	Ir	Pt	Au	Hg	Tl	Pb	Bi	Po	At	Rn
7	87	88	89	104	105	106	107	108	109	110	111	112						
	Fr	Ra	Ac	Rf	Db	Sg	Bh	Hs	Mt	Ds	Rg							
Lanthanides 6	58	59	60	61	62	63	64	65	66	67	68	69	70	71				
	Ce	Pr	Nd	Pm	Sm	Eu	Gd	Tb	Dy	Ho	Er	Tm	Yb	Lu				
Actinides 7	90	91	92	93	94	95	96	97	98	99	100	101	102	103				
	Th	Pa	U	Np	Pu	Am	Cm	Bk	Cf	Es	Fm	Md	No	Lr				
															Inner transition elements			

Copyright © 2008 Pearson Education, Inc., publishing as Pearson Addison-Wesley.

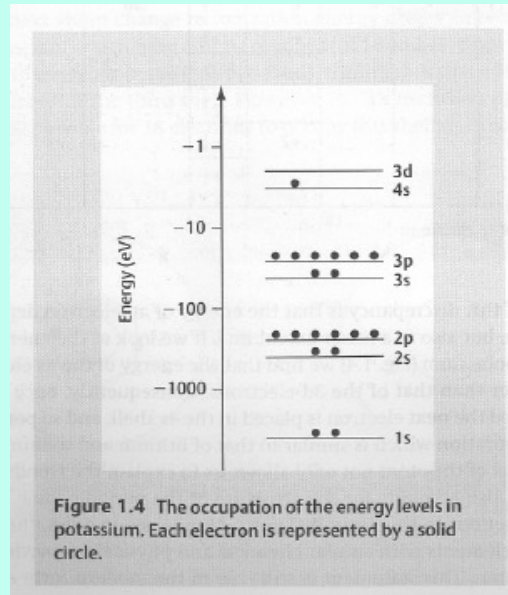

鉀原子

Period 1	1																	2	
	H																	He	
Period 2	3	4											5	6	7	8	9	10	
	Li	Be											B	C	N	O	F	Ne	
Period 3	11	12											13	14	15	16	17	18	
	Na	Mg	Transition elements										Al	Si	P	S	Cl	Ar	
Period 4	19	20	21	22	23	24	25	26	27	28	29	30	31	32	33	34	35	36	
	K	Ca	Sc	Ti	V	Cr	Mn	Fe	Co	Ni	Cu	Zn	Ga	Ge	As	Se	Br	Kr	
Period 5	37	38	39	40	41	42	43	44	45	46	47	48	49	50	51	52	53	54	
	Rb	Sr	Y	Zr	Nb	Mo	Tc	Ru	Rh	Pd	Ag	Cd	In	Sn	Sb	Te	I	Xe	
Period 6	55	56	57	72	73	74	75	76	77	78	79	80	81	82	83	84	85	86	
	Cs	Ba	La	Hf	Ta	W	Re	Os	Ir	Pt	Au	Hg	Tl	Pb	Bi	Po	At	Rn	
Period 7	87	88	89	104	105	106	107	108	109	110	111	112							
	Fr	Ra	Ac	Rf	Db	Sg	Bh	Hs	Mt	Ds	Rg								
Lanthanides 6				58	59	60	61	62	63	64	65	66	67	68	69	70	71		
				Ce	Pr	Nd	Pm	Sm	Eu	Gd	Tb	Dy	Ho	Er	Tm	Yb	Lu		
Actinides 7				90	91	92	93	94	95	96	97	98	99	100	101	102	103		
				Th	Pa	U	Np	Pu	Am	Cm	Bk	Cf	Es	Fm	Md	No	Lr		
				Inner transition elements															

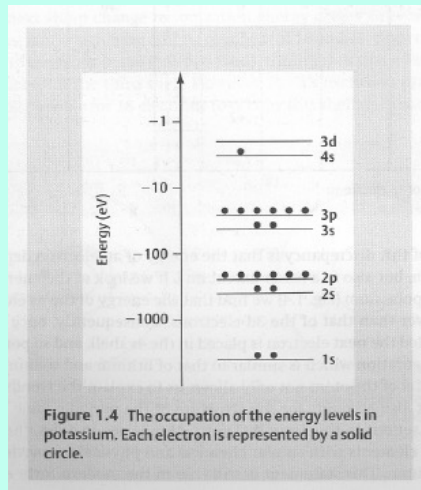

如同在原子中將電子一個個由下往上填。

在固體中也是將電子在能帶中一個個由下往上填。

固體鈉1s的能帶來自原子鈉1s的能階。能帶中的狀態數是 $2N$ 。

原來原子鈉1s的能階有二個電子，因此有 $2N$ 顆電子可以填。正好填滿！

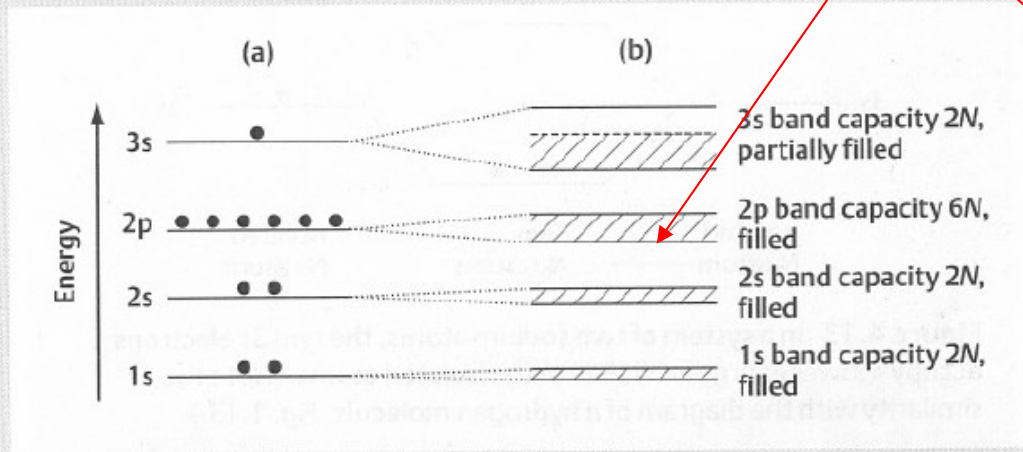
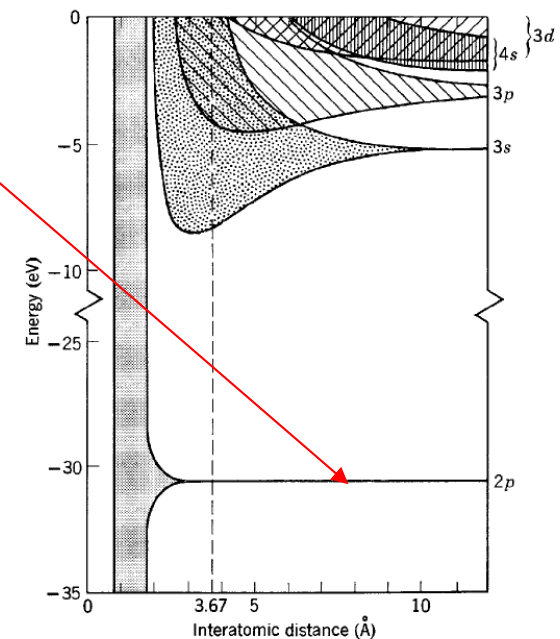
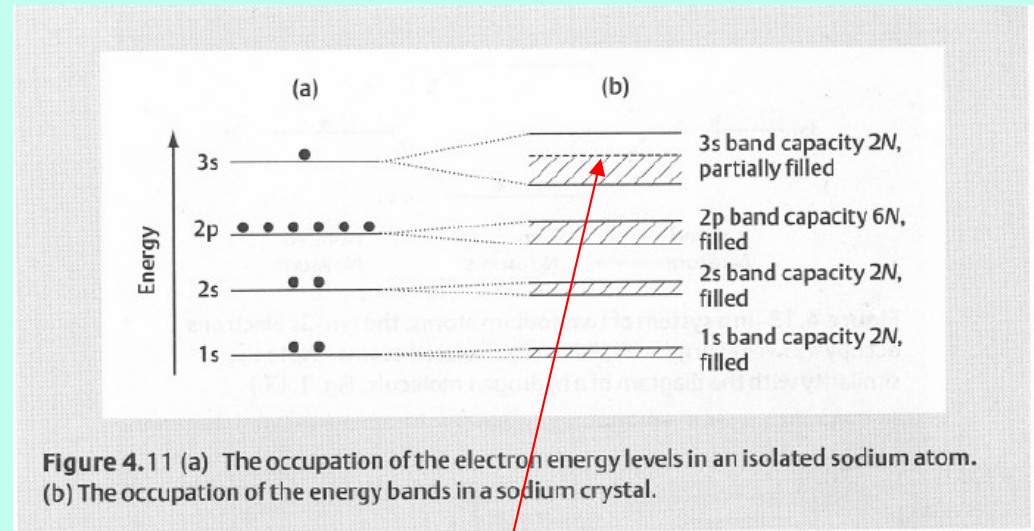
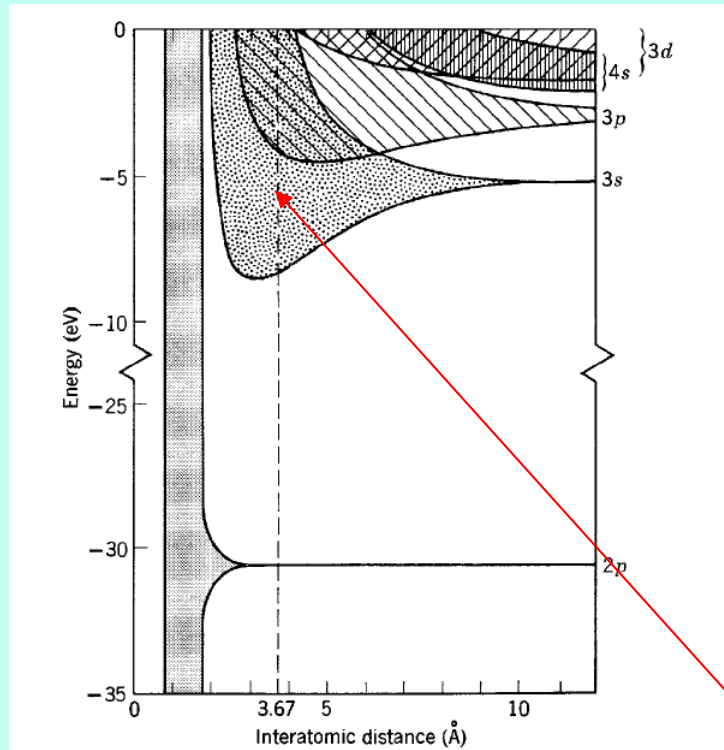

Figure 4.11 (a) The occupation of the electron energy levels in an isolated sodium atom. (b) The occupation of the energy bands in a sodium crystal.





固體鈉3s的能帶則是原子鈉3s及3p的能階的混合。能帶中的狀態數大於 $2N$ 。原來原子鈉3s的能階有二個電子，因此只有 $2N$ 顆電子可以填。無法填滿！

如果電子恰好填滿一個能帶（Valence），這些能帶中的電子無處可去！如同單一原子內的電子，需要很大能量才能克服間隙，改變狀態。如此電子即使不再被束縛於單一原子旁，但也不是機動的。這樣的固體無法導電，是絕緣體。

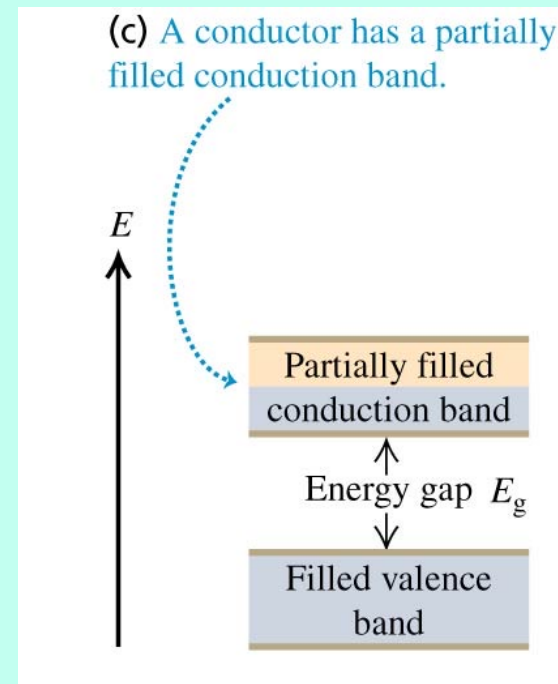
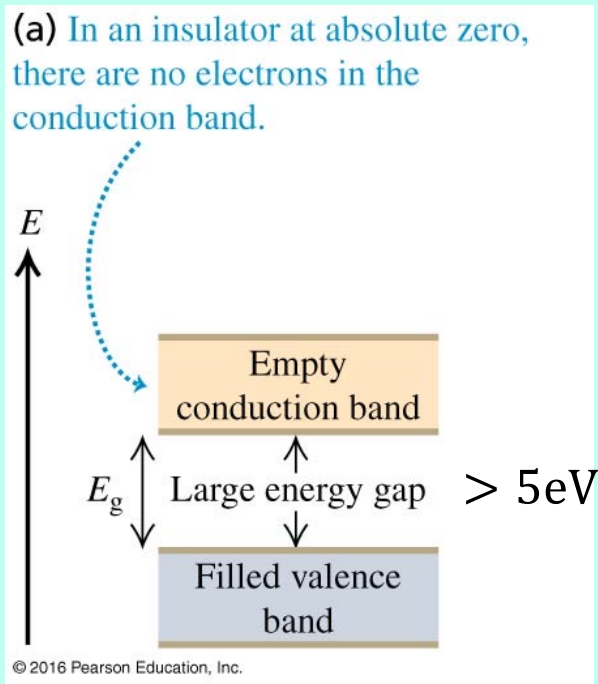

但如果電子未填滿能帶(稱Conduction)，未滿能帶內的電子很容易改變狀態。只要些許能量就能讓它激發到較高的能態。這些電子非常機動而自由，稱為導電電子。這樣的固體就可以導電，就是導體。於是連續卻有間隙的能帶energy band是固體導電性的關鍵。

如果電子恰好填滿一個能帶（Valence），這些能帶中的電子無處可去！

需要很大能量才能克服間隙，才能改變狀態。

如此電子即使不再被束縛，但完全不能自由。這樣的固體無法導電，是絕緣體。

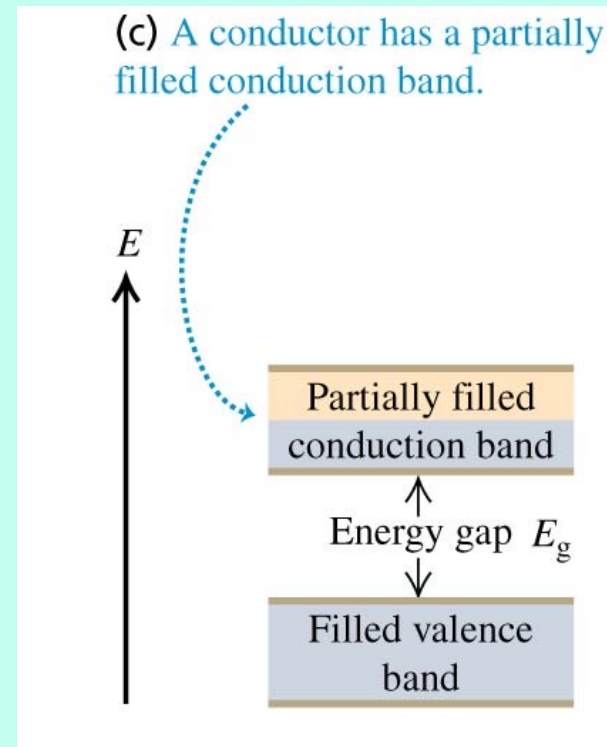
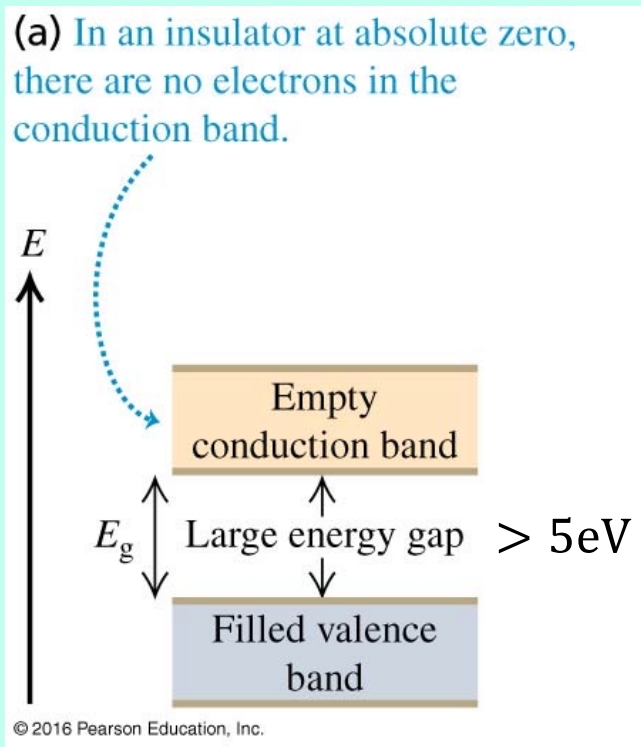

如果電子未填滿能帶（稱Conduction），未滿能帶內的電子很容易改變狀態。

只要些許能量就能讓它激發到其他能態。

這些電子非常自由，可以移動。這樣的固體就可以導電，就是導體。

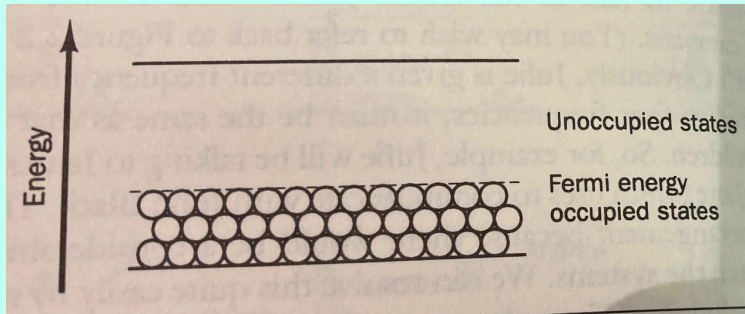

未加電壓

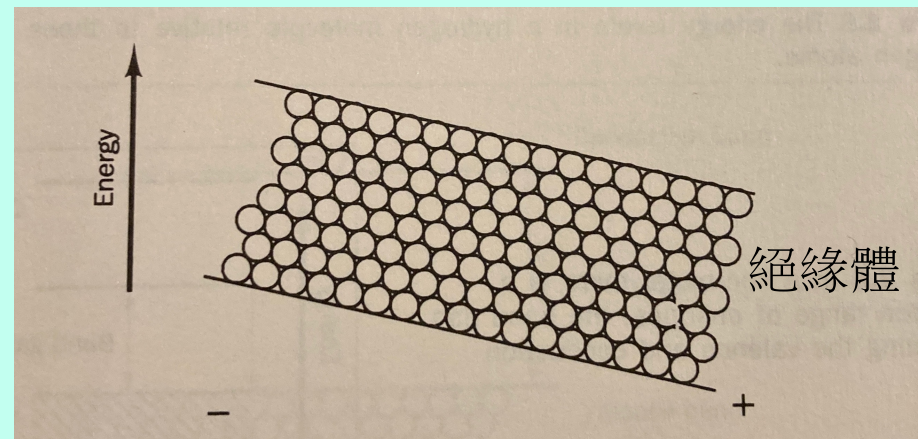
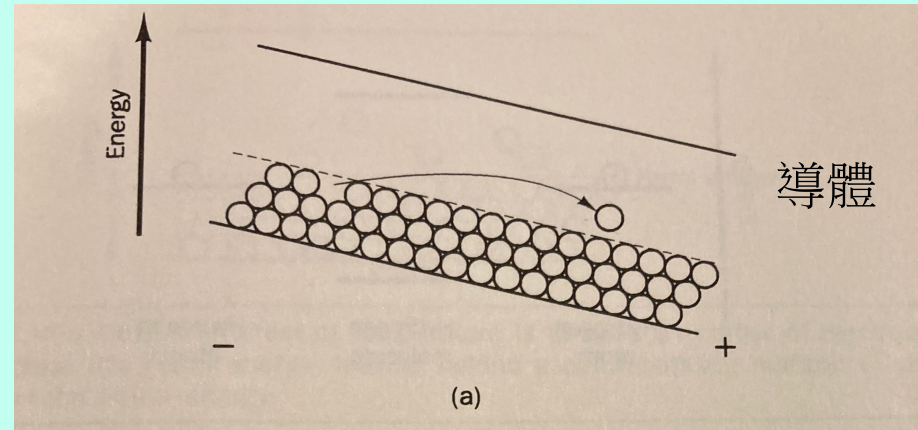

加電壓

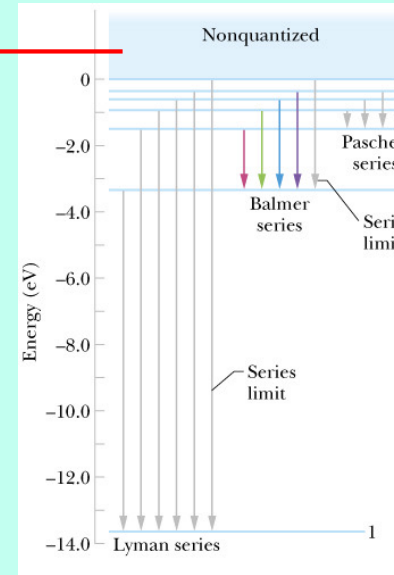
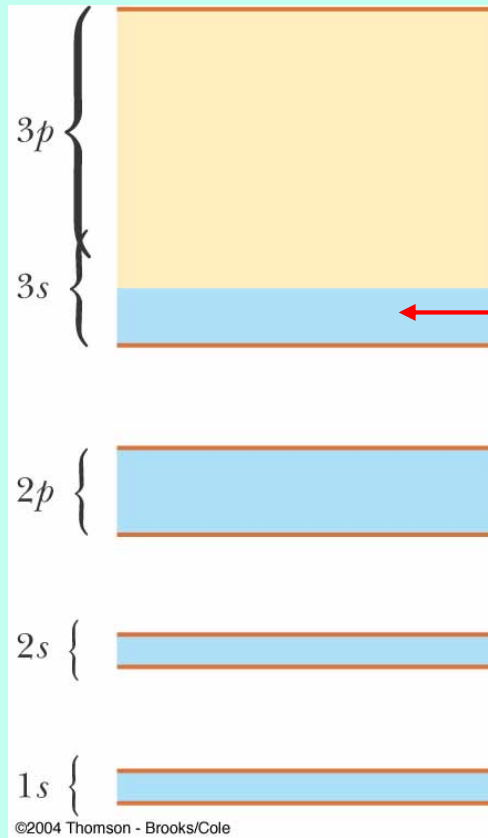

在未填滿的能帶內的電子能態，感覺就像原子能態中的連續能量自由態！

可以證明這些電子在固體內完全自由移動。彷彿沒有其他原子成分存在一般。

就如同氣體中的分子一樣！

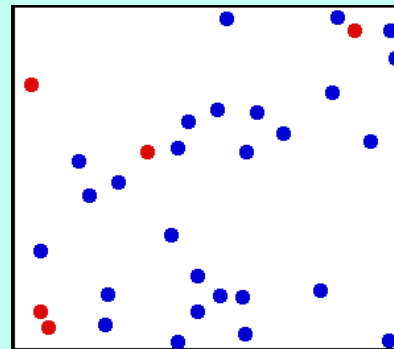

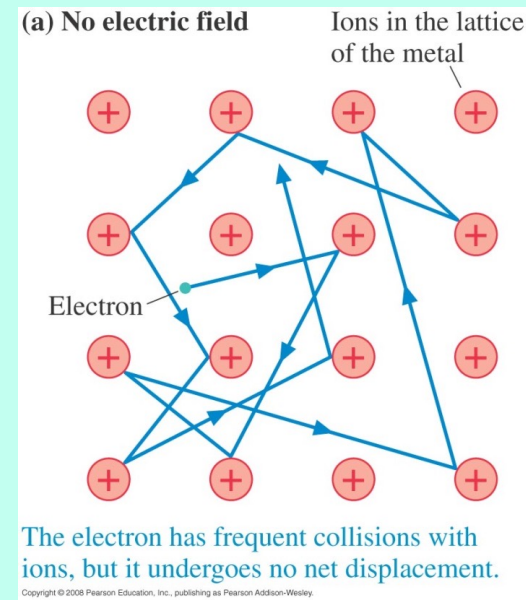
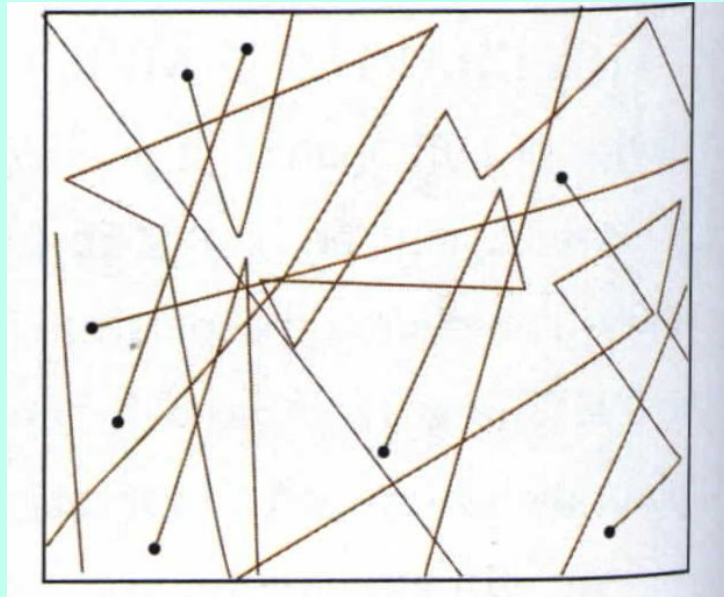

在固體中導電電子很像氣體分子！這就稱為**自由電子模型**。

即使沒有外加電場，電子也是在導體中如氣體分子般混亂地移動！

這個模型有時就稱為**無交互作用的理想電子氣體**。電子因此作自由運動。

但電子在自由運動間會撞擊晶格的離子而改變速度。

理想氣體以氣體分子的Maxwell速度分布可以推導出所有性質。

理想電子氣體也有電子能量分布。速率比同溫度Maxwell速度分布還快。

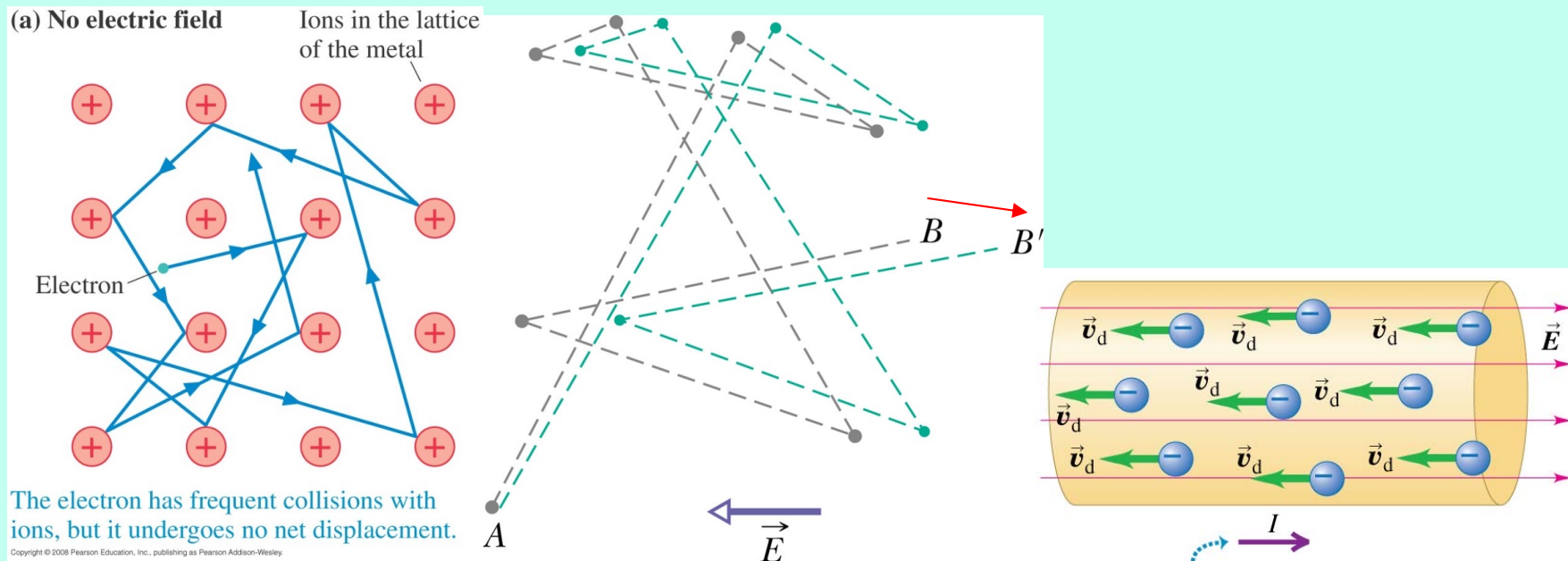

即使沒有外加電場，導體中電子也不是靜止不動的！
 但每一個電子的位移彼此無關，平均總位移為零！也就沒有電流。
 若是加上一個電場，所有自由電子在同一方向會多一個位移！
 電子平均總位移不為零！這就形成了漂移，也就產生電流。
 我們把平均漂移速度計為 v_d

我們可以估計電子平均漂移速度 v_d ！

電場對電子產生一加速度： $a = \frac{F}{m} = \frac{eE}{m}$

這是等加速度運動，電子速度一直增加，直到與離子碰撞後大致歸零。

我們可以兩次碰撞間，電子的平均速度，來估計電子漂移的平均速度。

平均漂移速度 $v_d = a\tau = \frac{e\tau}{m} E$ τ 是兩次碰撞間的平均間隔時間

平均漂移速度與電場成正比。

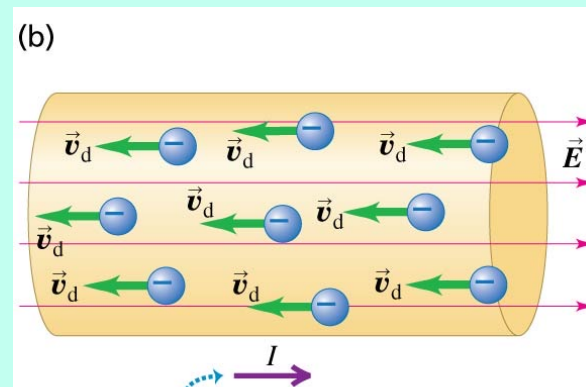
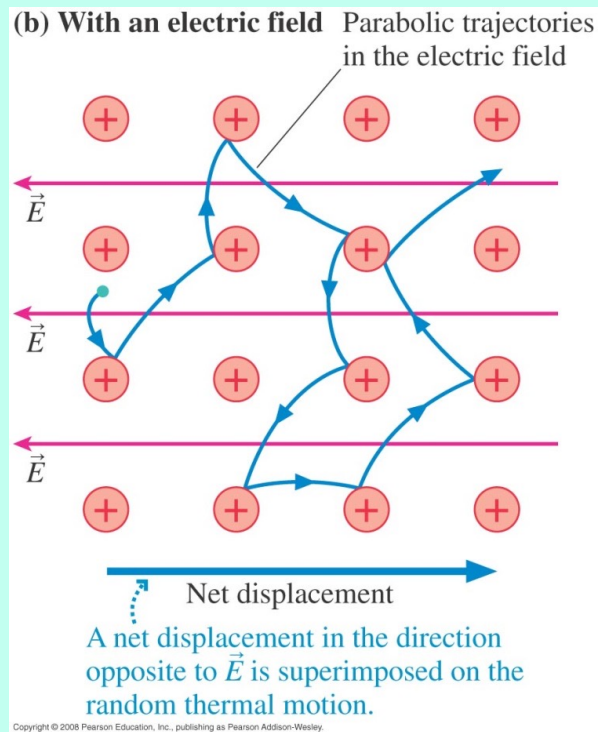

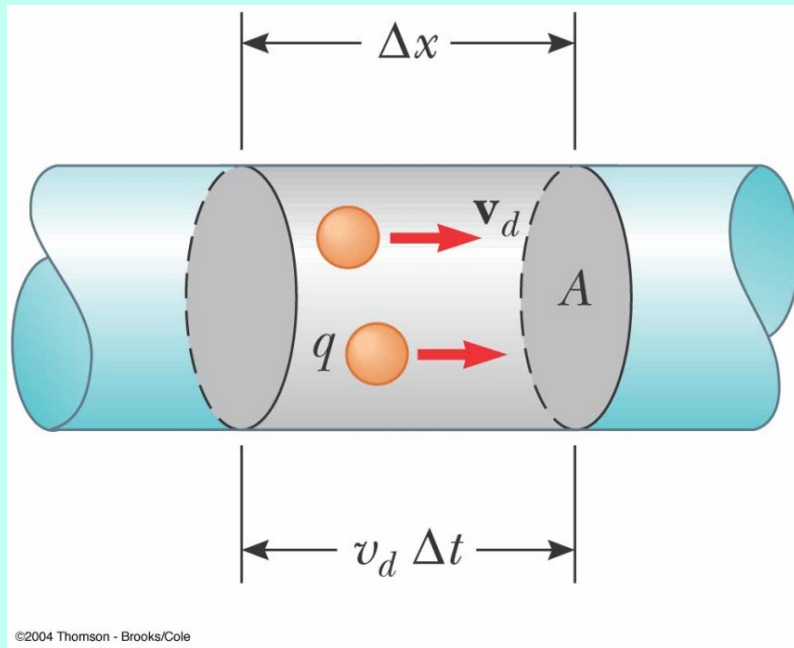

©2004 Thomson - Brooks/Cole

取 Δt ，在此時間內通過截面 A 的電荷：
一定就在左圖灰色體積範圍內：

$$q = (A\Delta x) \cdot ne = neAv_d\Delta t$$

$$i = \frac{q}{\Delta t} = neAv_d$$

電流密度為單位面積的電流。

$$j = \frac{i}{A} = nev_d$$

電流密度與平均漂移速度成正比。

平均漂移速度與電場成正比。

$$v_d = a\tau = \frac{e\tau}{m} E$$

電流密度與平均漂移速度成正比。

$$j = \frac{i}{A} = nev_d$$

τ 與外加電場無關，可視為一個常數。

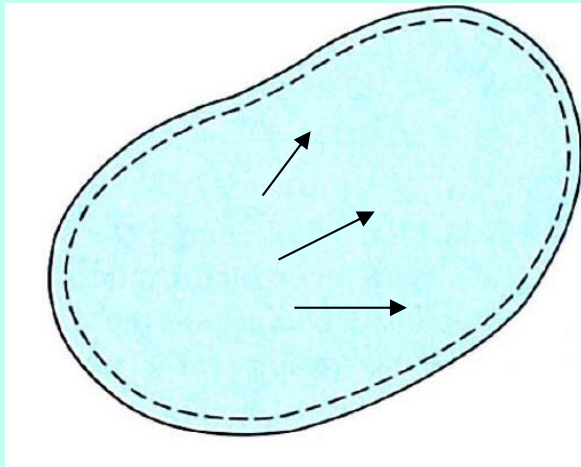

$$j = \left(\frac{e^2 n \tau}{m} \right) E$$

歐姆定律

$$E = \left(\frac{m}{e^2 n \tau} \right) j$$

Georg Simon Ohm



$$\vec{E} = \rho \vec{j}$$

$$\rho = \frac{m}{e^2 n \tau}$$

ρ 是電阻率 Resistivity，是材料的性質

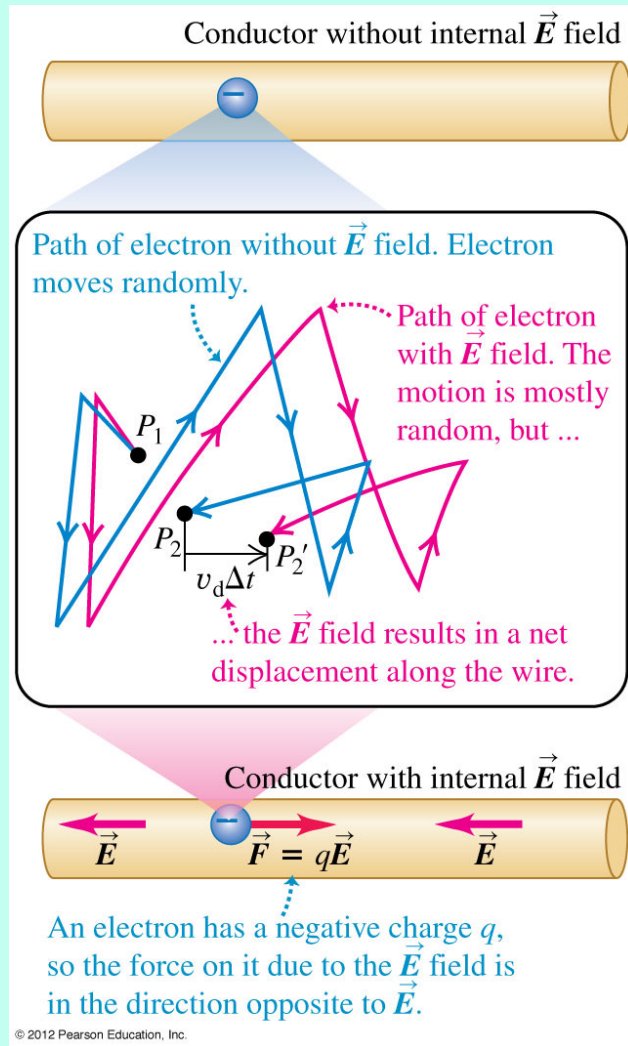

$$v_{\text{rms}} \sim 10^6 \text{ m/s}$$

但電子的熱運動方向隨機，因此互相抵消。
討論導電性時，可以忽略而等價以下圖表示。

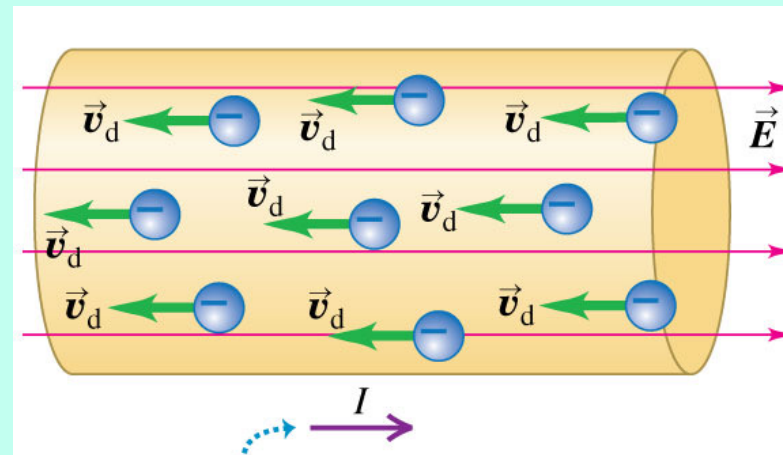

$$v_d \sim 10^{-4} \text{ m/s} \ll v_{\text{rms}}$$

漂移速度遠小於熱速度 v_{rms} ，因此 τ 由 v_{rms} 決定
因此 τ 與外加電場無關。 τ 可視為一個常數

TABLE 25.1 Resistivities at Room Temperature (20°C)

Substance		ρ ($\Omega \cdot \text{m}$)	Substance		ρ ($\Omega \cdot \text{m}$)	
Conductors			Semiconductors			
Metals	Silver	1.47×10^{-8}	Pure carbon (graphite)		3.5×10^{-5}	
	Copper	1.72×10^{-8}	Pure germanium		0.60	
	Gold	2.44×10^{-8}	Pure silicon		2300	
	Aluminum	2.75×10^{-8}	Insulators			
	Tungsten	5.25×10^{-8}	Amber		5×10^{14}	
	Steel	20×10^{-8}	Glass		$10^{10} - 10^{14}$	
	Lead	22×10^{-8}	Lucite		$> 10^{13}$	
	Mercury	95×10^{-8}	Mica		$10^{11} - 10^{15}$	
	Alloys	Manganin (Cu 84%, Mn 12%, Ni 4%)	44×10^{-8}	Quartz (fused)		75×10^{16}
		Constantan (Cu 60%, Ni 40%)	49×10^{-8}	Sulfur		10^{15}
Nichrome		100×10^{-8}	Teflon		$> 10^{13}$	
			Wood		$10^8 - 10^{11}$	

© 2016 Pearson Education, Inc.

$$\rho = \frac{m}{e^2 n \tau}$$

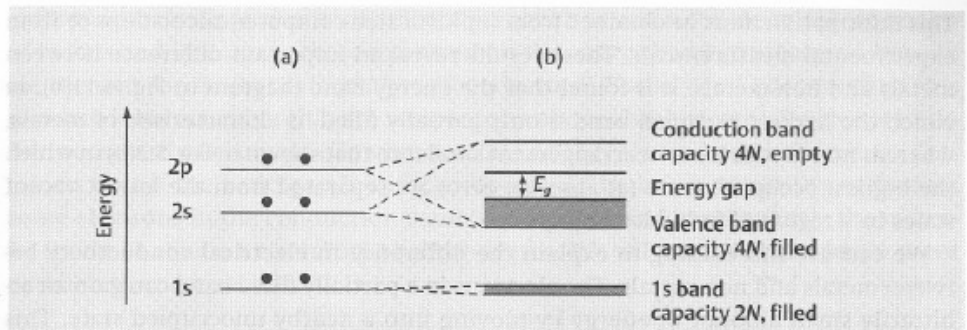

Figure 5.2 The occupation of (a) the energy levels in an isolated carbon atom, and (b) the energy bands in a diamond crystal. Notice that there is an energy range E_g separating the highest occupied states (in the valence band) from the lowest vacant states (in the conduction band). This is a characteristic feature of all insulators.

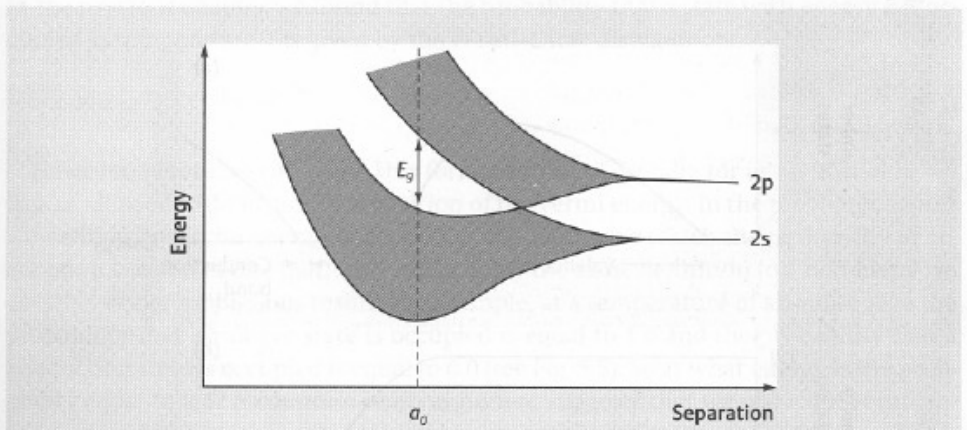
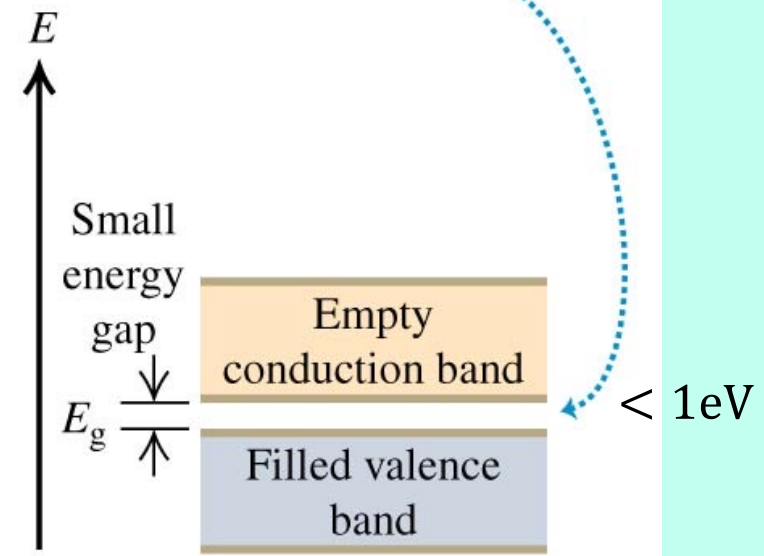

Figure 5.3 The energy levels of the 2s and 2p states for a group of N carbon atoms as a function of the separation of the atoms.

半導體 Semiconductor

(b) A semiconductor has the same band structure as an insulator but a smaller gap between the valence and conduction bands.



若全滿的Valence能帶與全空的Conduction能帶間隙很小時，情況與絕緣體很不一樣！

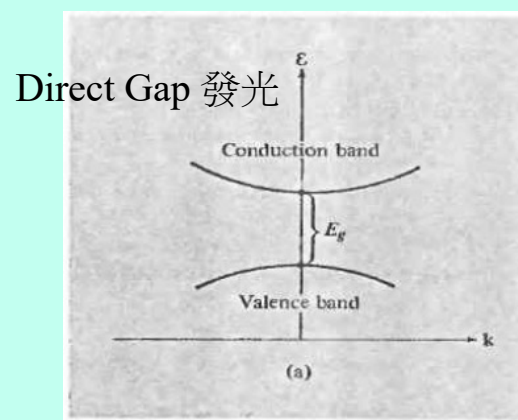
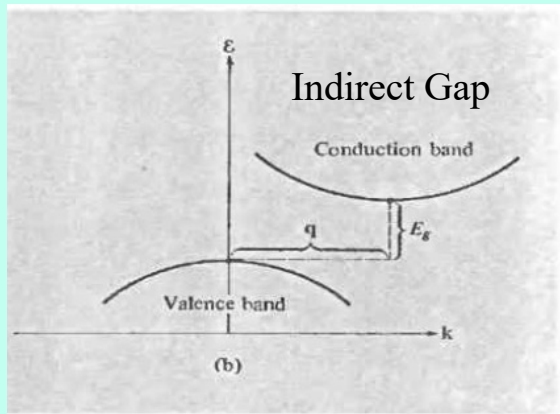

						2
	5	6	7	8	9	10
	B	C	N	O	F	Ne
	13	14	15	16	17	18
	Al	Si	P	S	Cl	Ar
30	31	32	33	34	35	36
Zn	Ga	Ge	As	Se	Br	Kr
48	49	50	51	52	53	54
Cd	In	Sn	Sb	Te	I	Xe
80	81	82	83	84	85	86
Hg	Tl	Pb	Bi	Po	At	Rn
112						

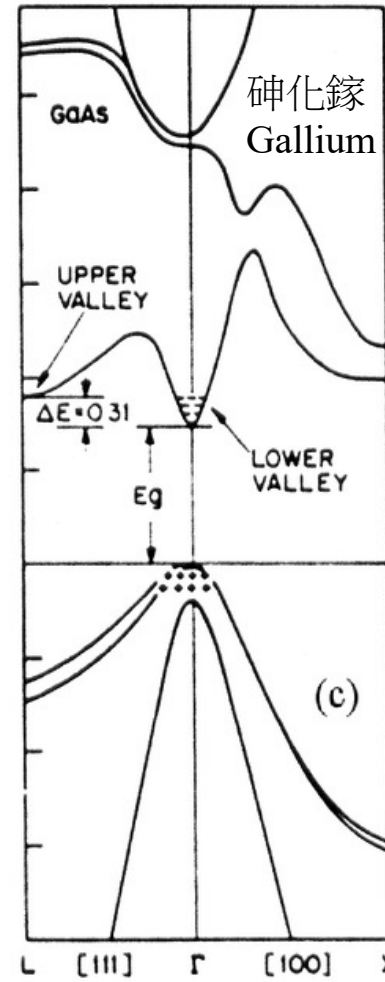
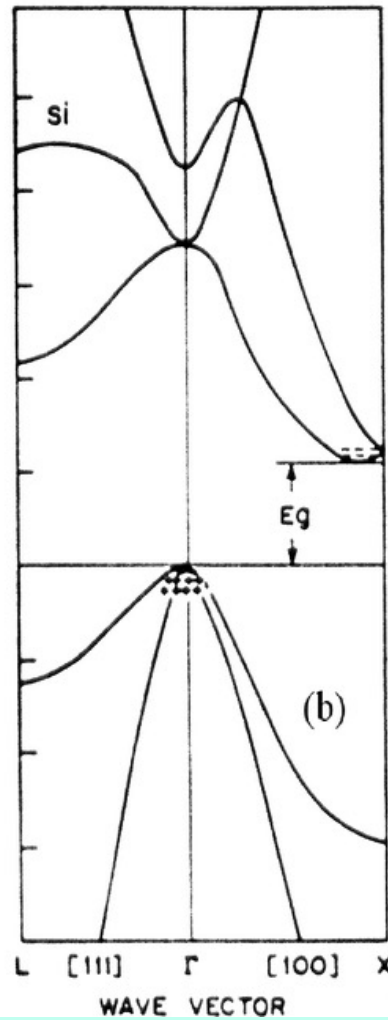
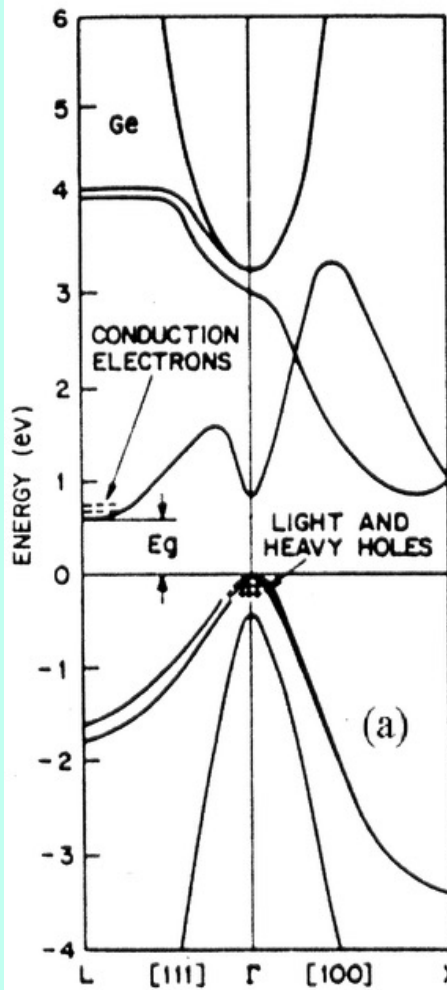

砷化鎵
Gallium arsenide

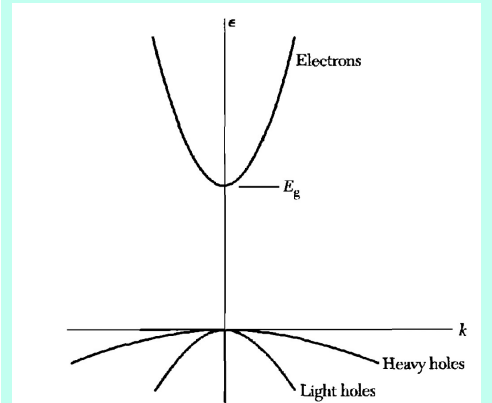

半導體 Semiconductor

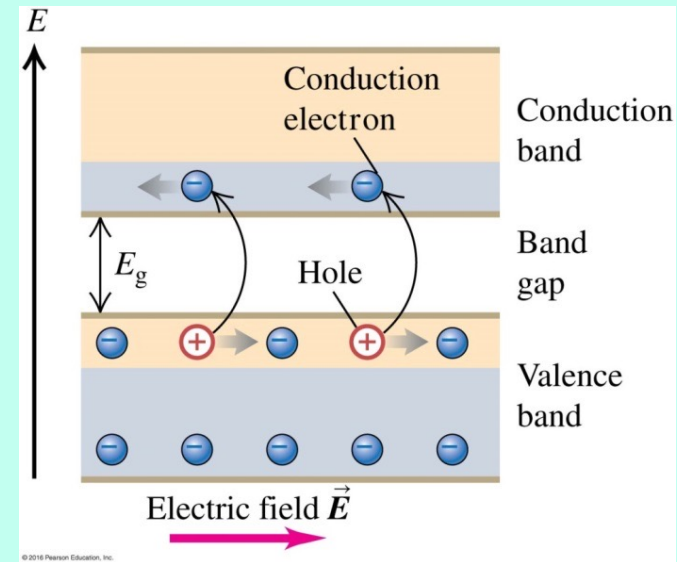
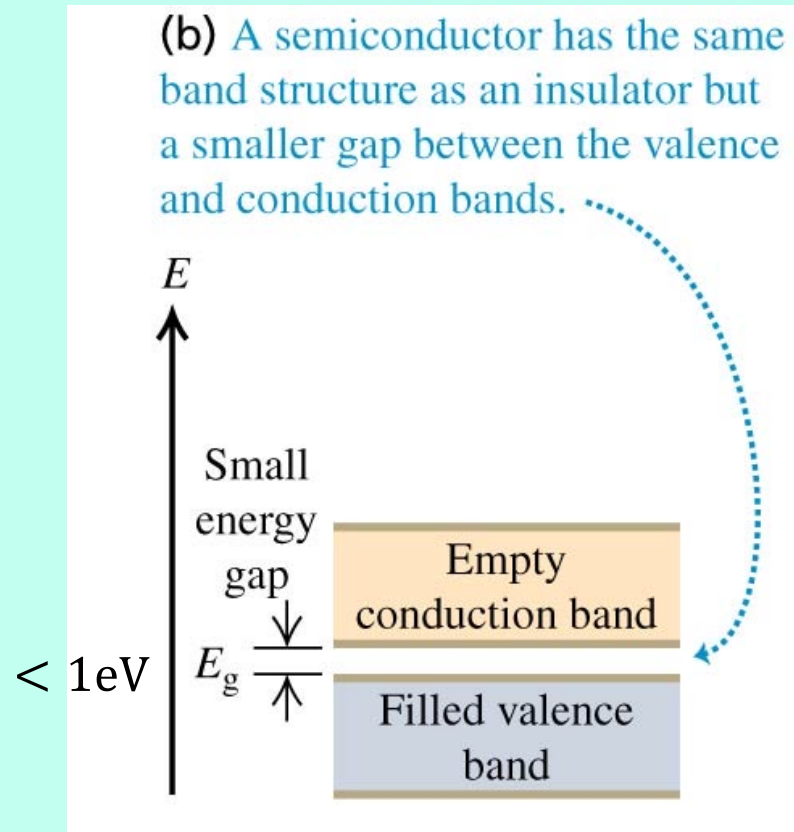

半導體的能帶間隙小，在室溫時即可以有電子由Valence跳上Conduction。
Conduction帶內的電子及Valence帶內的電洞形成導電的載體carrier。

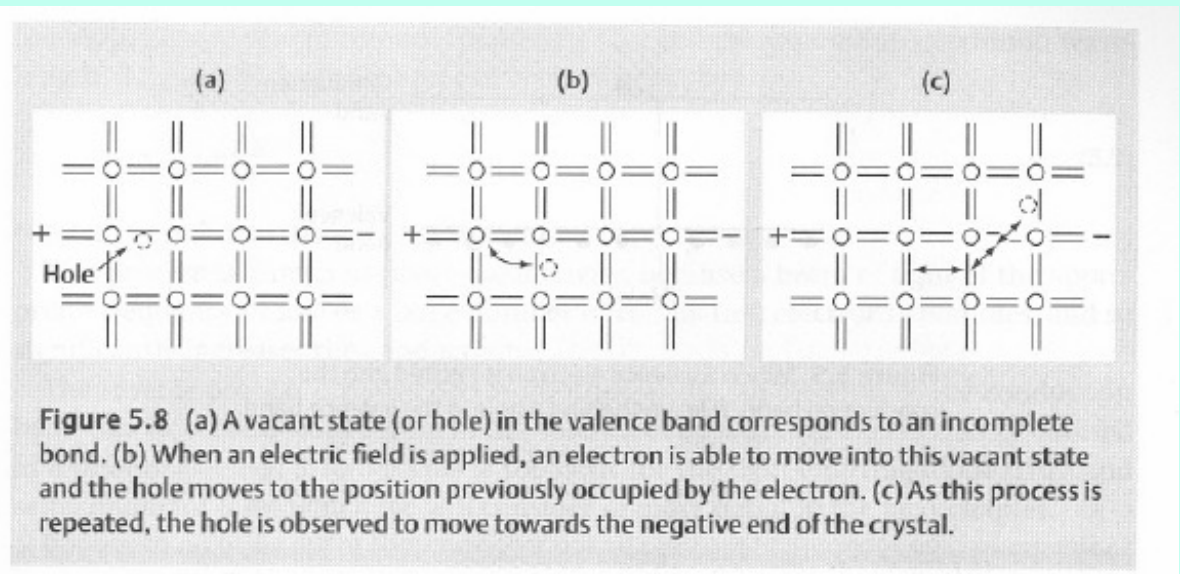
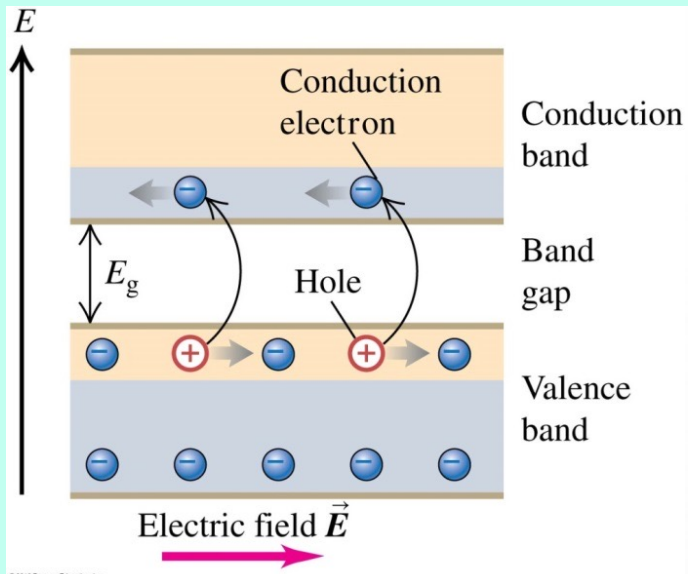

電洞也能導電！

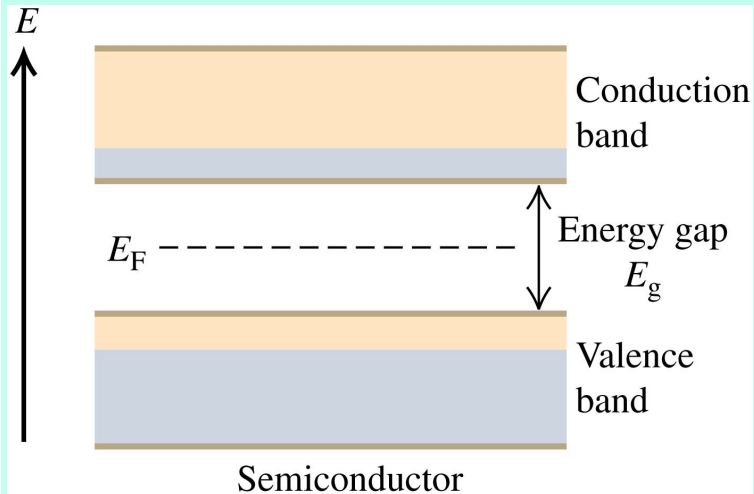

$$n \propto e^{-E_g/2kT}$$

導電電子密度由能隙決定！

$$\frac{E_g}{kT} \sim \frac{0.2\text{eV}}{8.617 \times 10^{-5} \text{eV/K} \cdot 300\text{K}} \sim 7.736$$

$$n \propto 2.00 \times 10^{-2}$$

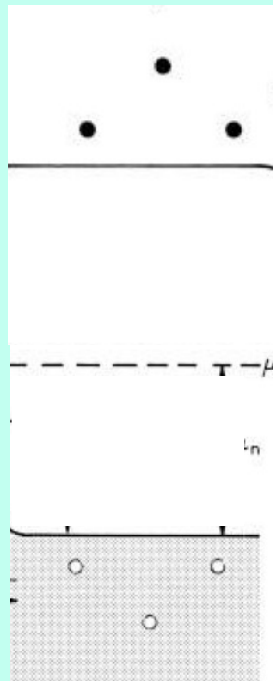

EXAMPLE 42.9 JUMPING A BAND GAP

Consider a material with the band structure described above, with its Fermi energy in the middle of the gap (Fig. 42.24). Find the probability that a state at the bottom of the conduction band is occupied at $T = 300$ K, and compare that with the probability at $T = 310$ K, for band gaps of (a) 0.200 eV; (b) 1.00 eV; (c) 5.00 eV.

SOLUTION

IDENTIFY and SET UP: The Fermi-Dirac distribution function gives the probability that a state of energy E is occupied at temperature T . Figure 42.24 shows that the state of interest at the bottom of the conduction band has an energy $E = E_F + E_g/2$ that is greater than the Fermi energy E_F , with $E - E_F = E_g/2$. Figure 42.23 shows that

42.24 Band structure of a semiconductor. At absolute zero a completely filled valence band is separated by a narrow energy gap E_g of 1 eV or so from a completely empty conduction band. At ordinary temperatures, a number of electrons are excited to the conduction band.

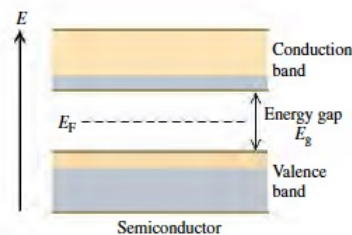

the higher the temperature, the larger the fraction of electrons with energies greater than the Fermi energy.

EXECUTE: (a) When $E_g = 0.200$ eV,

$$\frac{E - E_F}{kT} = \frac{E_g}{2kT} = \frac{0.100 \text{ eV}}{(8.617 \times 10^{-5} \text{ eV/K})(300 \text{ K})} = 3.87$$

$$f(E) = \frac{1}{e^{3.87} + 1} = 0.0205$$

For $T = 310$ K, the exponent is 3.74 and $f(E) = 0.0231$, a 13% increase in probability for a temperature rise of 10 K.

(b) For $E_g = 1.00$ eV, both exponents are five times as large as in part (a), namely 19.3 and 18.7; the values of $f(E)$ are 4.0×10^{-9} and 7.4×10^{-9} . In this case the (low) probability nearly doubles with a temperature rise of 10-K.

(c) For $E_g = 5.0$ eV, the exponents are 96.7 and 93.6; the values of $f(E)$ are 1.0×10^{-42} and 2.3×10^{-41} . The (extremely low) probability increases by a factor of 23 for a 10-K temperature rise.

EVALUATE: This example illustrates two important points. First, the probability of finding an electron in a state at the bottom of the conduction band is extremely sensitive to the width of the band gap. At room temperature, the probability is about 2% for a 0.200-eV gap, a few in a thousand million for a 1.00-eV gap, and essentially zero for a 5.00-eV gap. (Pure diamond, with a 5.47-eV band gap, has essentially no electrons in the conduction band and is an excellent insulator.) Second, for any given band gap the probability depends strongly on temperature, and even more strongly for large gaps than for small ones.



SOLUTION

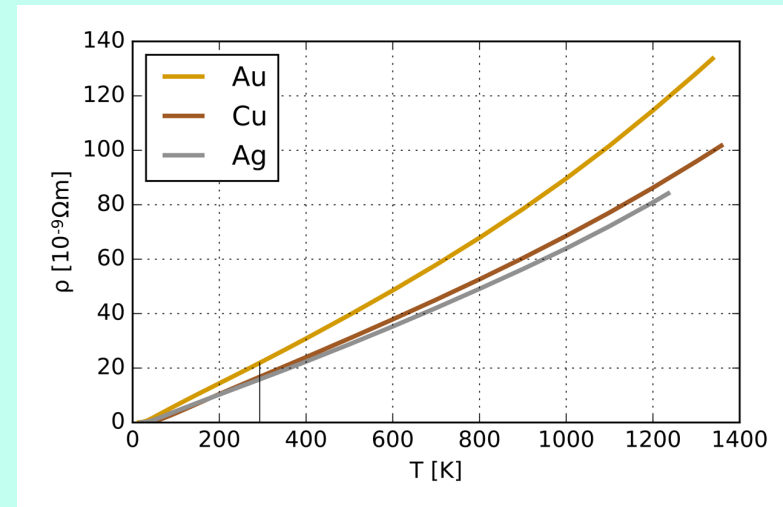
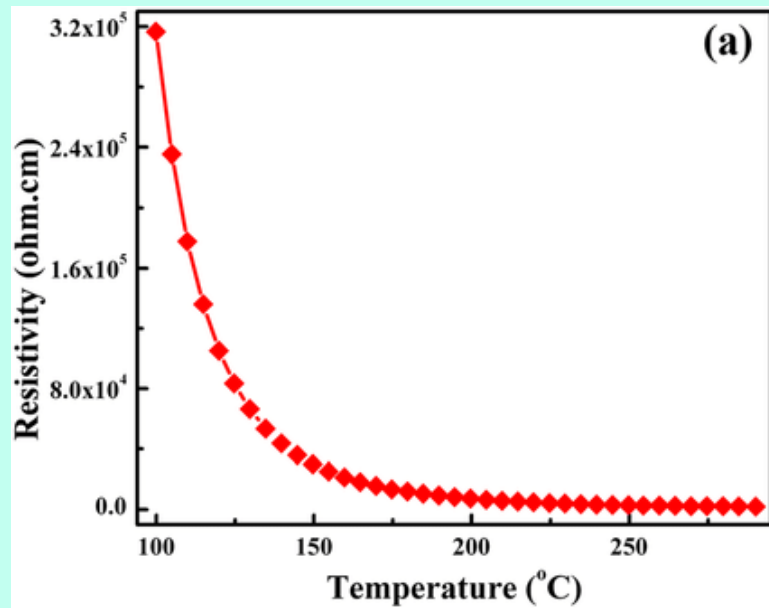

半導體的電阻率隨溫度增加快速降低。

相對的、導體的電阻率隨溫度增加而增加。

但 $E_g \sim 1.0\text{eV}$ 能跳上Conduction的電子數量還是少於導體，
電阻率比起導體還是來得大！

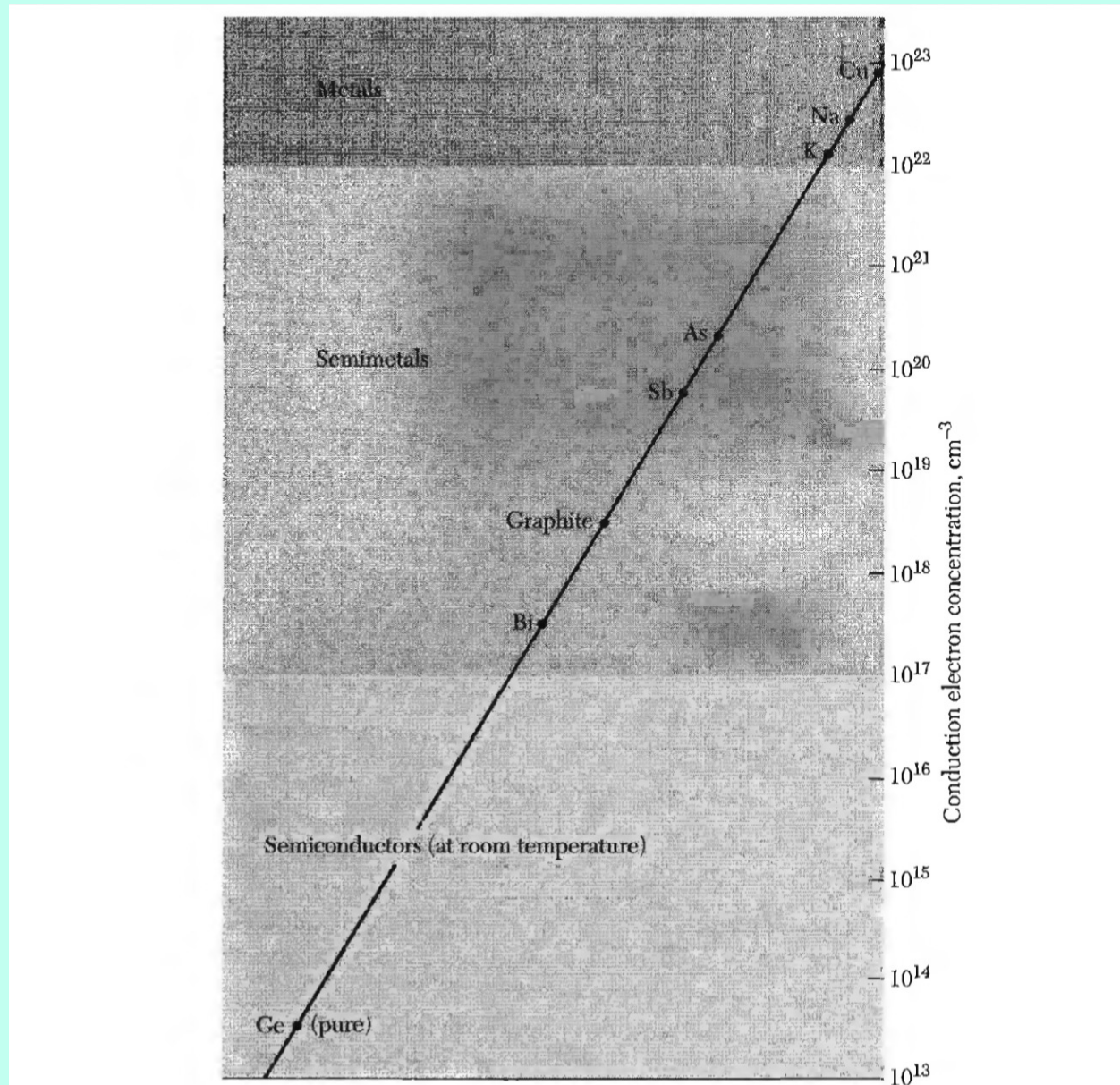
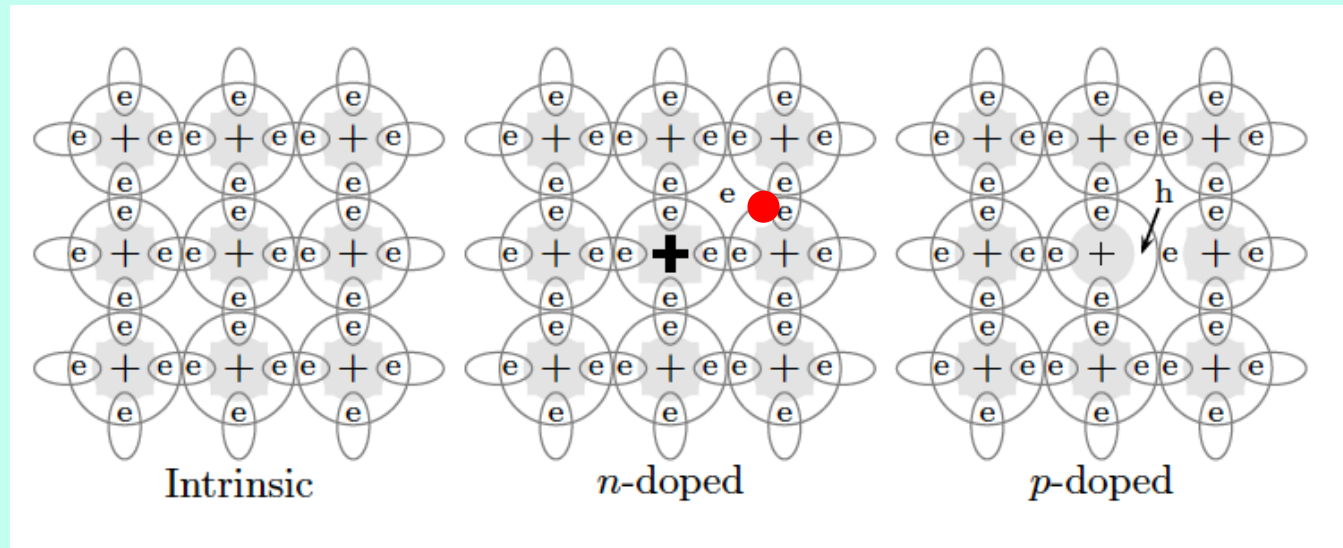
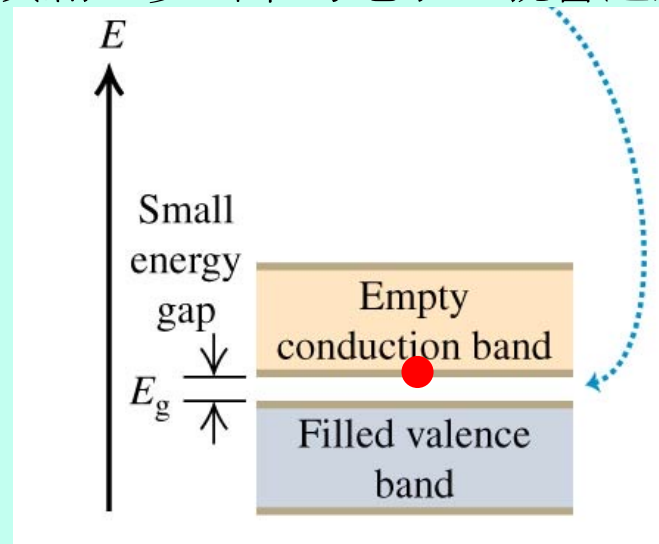

Figure 1 Carrier concentrations for metals, semimetals, and semiconductors. The semiconductor range may extend downward by increasing the impurity concentration, and the range can be extended downward to merge eventually with the insulator range.

如此晶體結構幾乎不變，但電子會多出一個。



價能帶已填滿，多出來的電子，就會進入全空的傳導帶。



但不完全.....

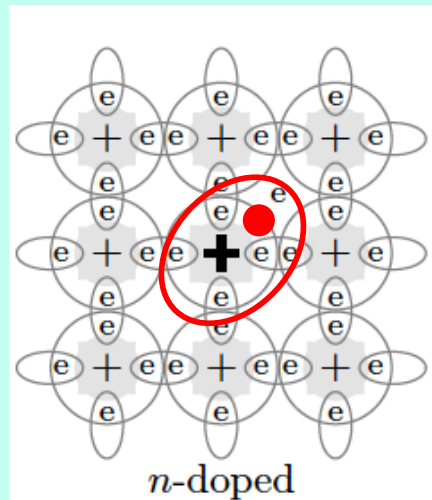

多出來的電子，與多出來的磷原子核正電荷，會如氫原子，形成束縛態。

但因此電子的有效質量一般小於電子質量，

而且必須考慮半導體內的介電性，一般極大。

因此束縛能 ~ 0.1 eV遠小於氫原子束縛能，以及能隙 E_G ，而半徑遠大 $\sim 30\text{\AA}$ 。

這些束縛態的能量略低於傳導帶下端，與導帶的間隙就是束縛能 ~ 0.1 eV。

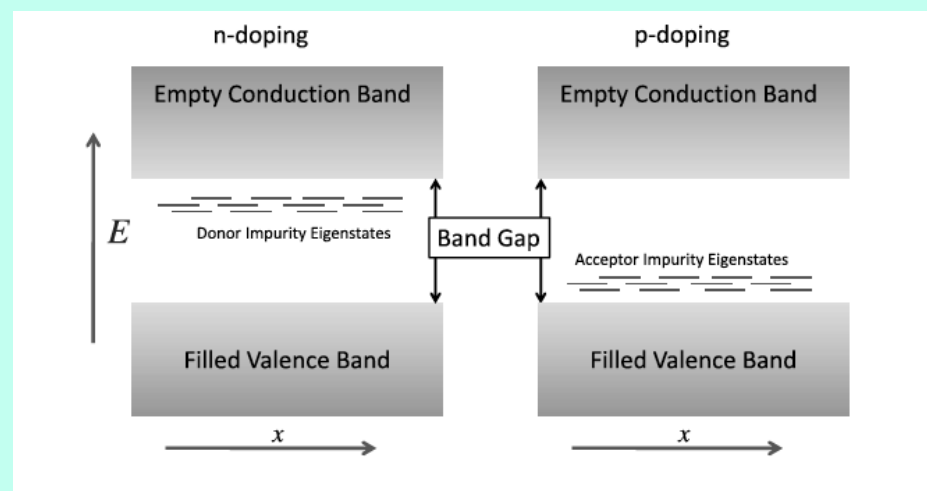

(a) A donor (*n*-type) impurity atom has a fifth valence electron that does not participate in the covalent bonding and is very loosely bound.

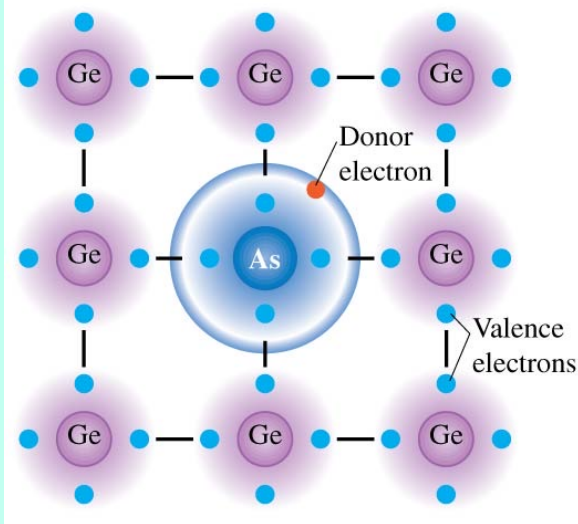

															2
										5	6	7	8	9	10
										B	C	N	O	F	Ne
										13	14	15	16	17	18
										Al	↓	↓	S	Cl	Ar
Transition elements															
23	24	25	26	27	28	29	30	31	32	33	34	35	36		
V	Cr	Mn	Fe	Co	Ni	Cu	Zn	Ga	Ge	As	Se	Br	Kr		
41	42	43	44	45	46	47	48	49	50	51	52	53	54		
Nb	Mo	Tc	Ru	Rh	Pd	Ag	Cd	In	Sn	Sb	Te	I	Xe		
73	74	75	76	77	78	79	80	81	82	83	84	85	86		

(b) Energy-band diagram for an *n*-type semiconductor at a low temperature. One donor electron has been excited from the donor levels into the conduction band.

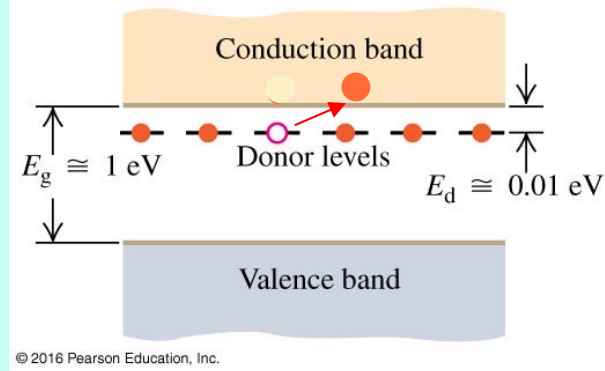

鍺 Ge
砷 As Arsenic

加入五價雜質提供鍵結以外多一顆電子。

此電子的能態，在傳導帶之下，且間隙極小，稱為Doner態。

因此室溫時即可以有大量電子跳上Conduction帶，可以導電。

作為載體的電子帶負電，此類固體稱為n type半導體。

(a) An acceptor (*p*-type) impurity atom has only three valence electrons, so it can borrow an electron from a neighboring atom. The resulting hole is free to move about the crystal.

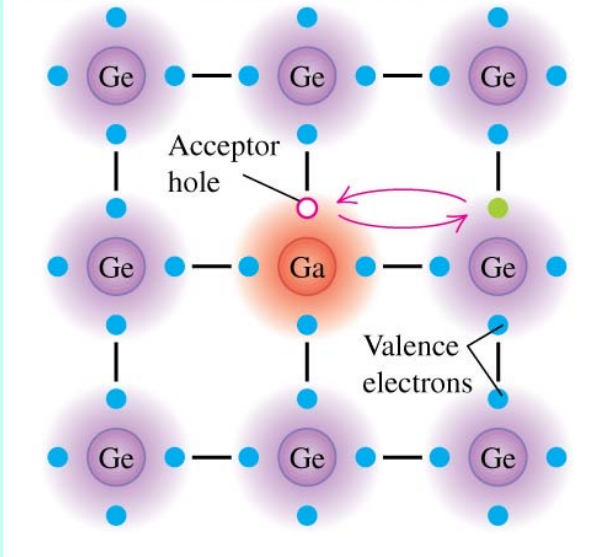

(b) Energy-band diagram for a *p*-type semiconductor at a low temperature. One acceptor level has accepted an electron from the valence band, leaving a hole behind.

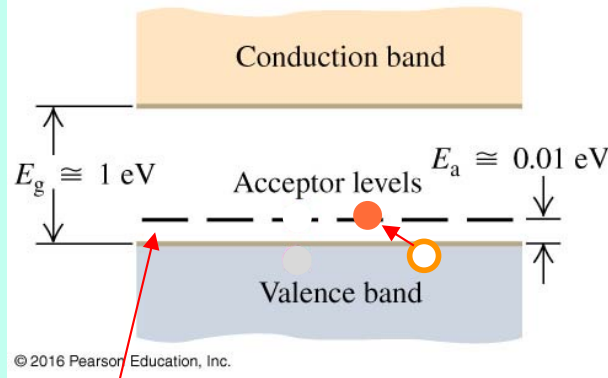

					2	
	5	6	7	8	9	10
	B	C	N	O	F	Ne
	13	14	15	16	17	18
	Al	Si	P	S	Cl	Ar
n	31	32	33	34	35	36
	Ga	Ge	As	Se	Br	Kr
	49	50	51	52	53	54
d	In	Sn	Sb	Te	I	Xe
	81	82	83	84	85	86

Ga Gallium 鎵

反之，加入三價雜質使鍵結內少一顆電子，等於價帶出現一個電洞。此電洞與帶負電原子核的束縛態，稱為Acceptor態，在價帶上方，間隙也極小，因此室溫時即可以有電子由價帶跳上空的Acceptor態。

價帶出現電洞，電洞可以移動，就可以導電。

作為載體的電洞帶正電，此類固體稱為p type半導體。

以帶正電的粒子來導電的固態導體，在自然界是不存在的，

因此這是一種人類利用半導體所發明的新材料

室溫下，雜質半導體內的電子與電洞分佈：

(b) Energy-band diagram for an *n*-type semiconductor at a low temperature. One donor electron has been excited from the donor levels into the conduction band.

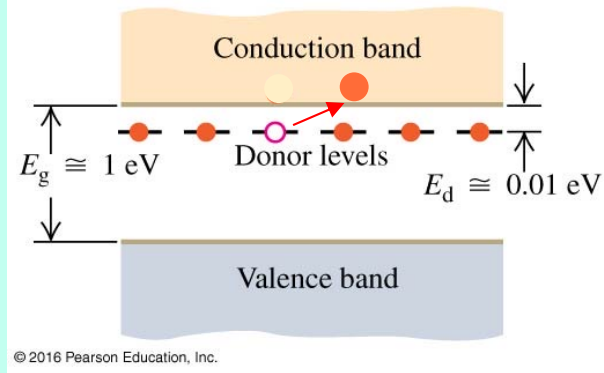

(b) Energy-band diagram for a *p*-type semiconductor at a low temperature. One acceptor level has accepted an electron from the valence band, leaving a hole behind.

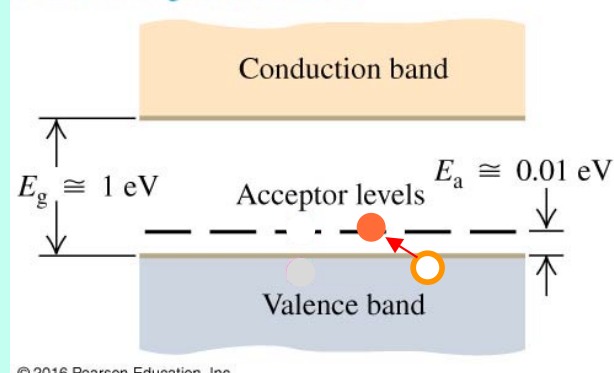

n type 半導體內，

因能量間隙 E_d 很小，定溫下，許多電子會由 Doner Level 上到傳導帶，如氫原子的游離。

在導帶上，這些電子的能量分佈大致是波茲曼分佈 $\sim e^{-(E-E_G)/kT}$ 。

p type 半導體內，電子從價帶跳上 Acceptor Level，也同理在價帶有電洞的分佈。

同時，還是有比較少的電子會跳上導帶，

在導帶上，這些電子的數量大致是波茲曼分佈 $\sim e^{-E_G/2kT}$ 。

將不同型的半導體組合在一起可以製造出各式半導體元件來控制電路中的電流：

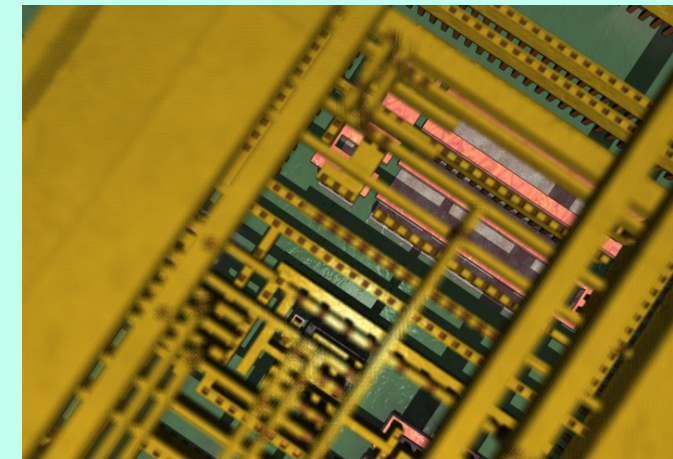
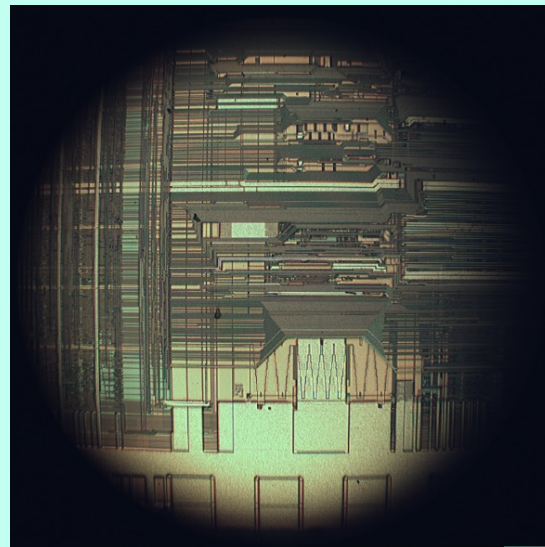
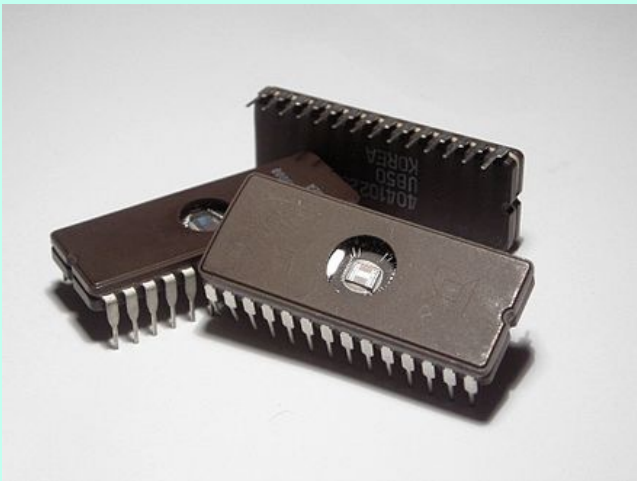
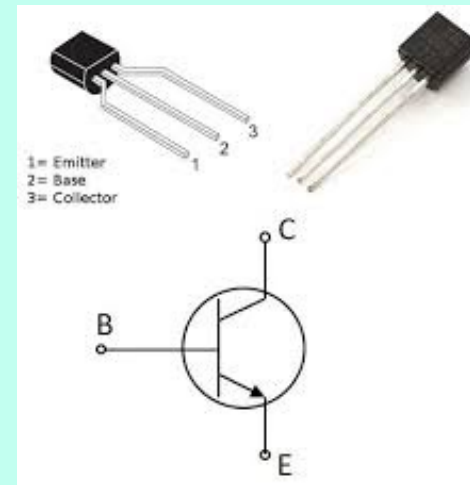
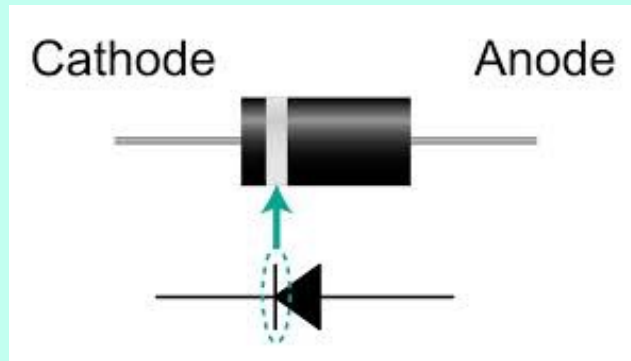

Integrated Circuit IC 積體電路

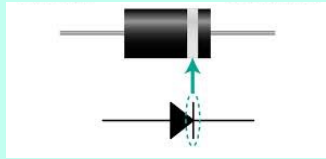

p-n Junction, Diode二極體：電流只能朝單一方向p→n流動！整流器

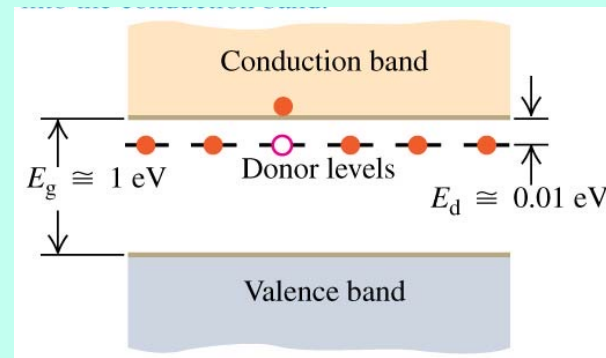
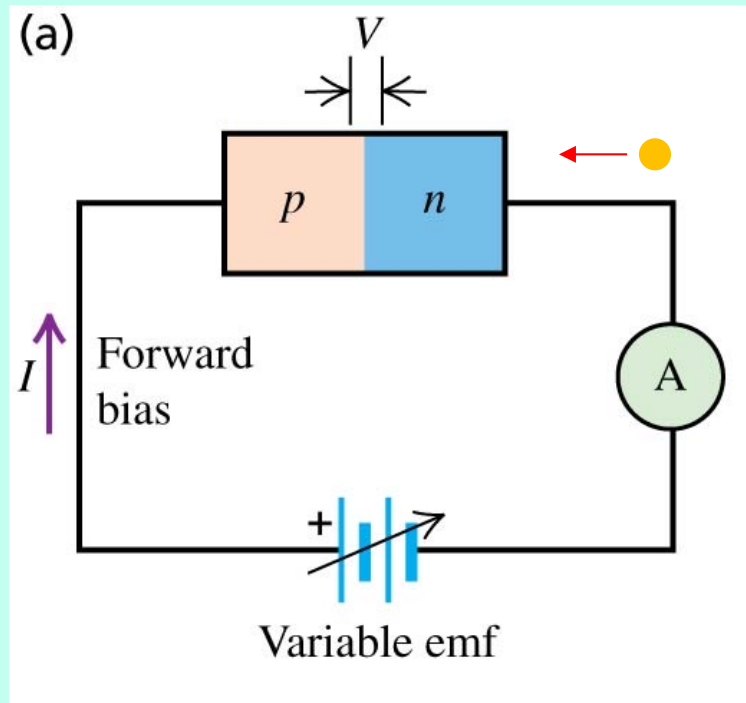

在Forward Bias流向，電子流入n，可以推動原來傳帶中電子流動。
同時，電子從p流走，等於加入電洞，電洞在p中可以流動到介面，與電子抵消。

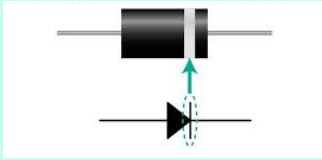

p-n Junction, Diode二極體：電流只能朝單一方向p→n流動！整流器

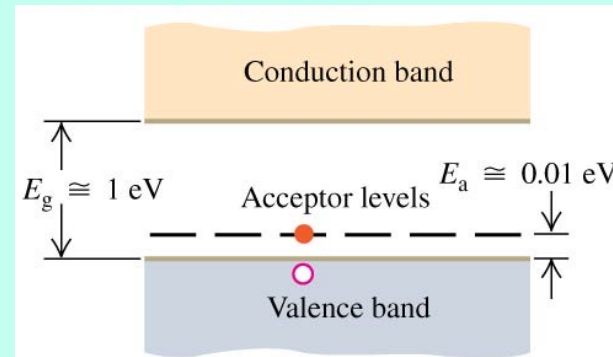
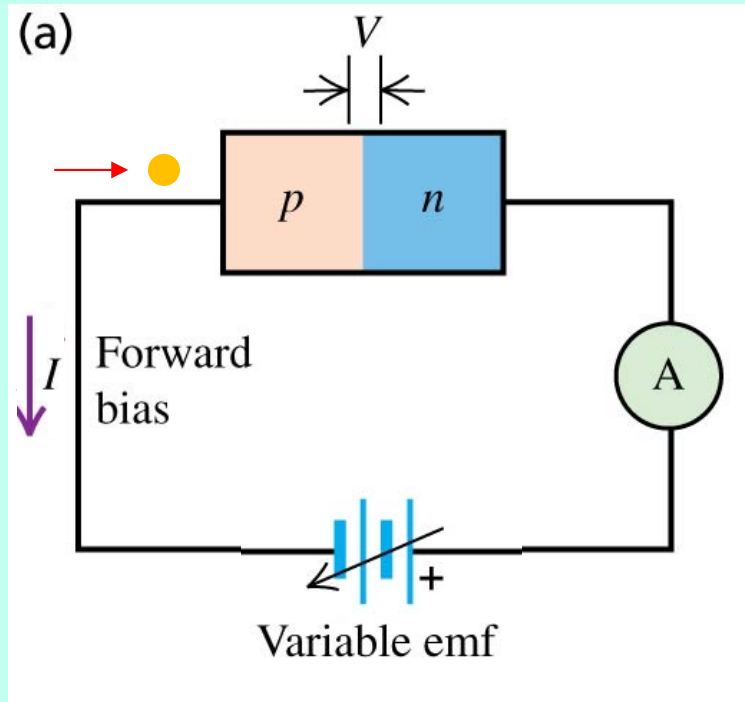

在Reverse Bias流向，電子從左流入p，只能填入電洞，能傳導的電洞反而消失了。
而p中的電子，根本無法流動。因此電子幾乎無法流過p，到達介面。

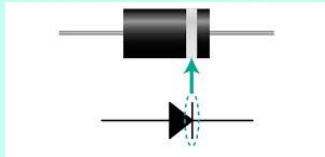

p-n Junction, Diode二極體：電流只能朝單一方向 $p \rightarrow n$ 流動！整流器

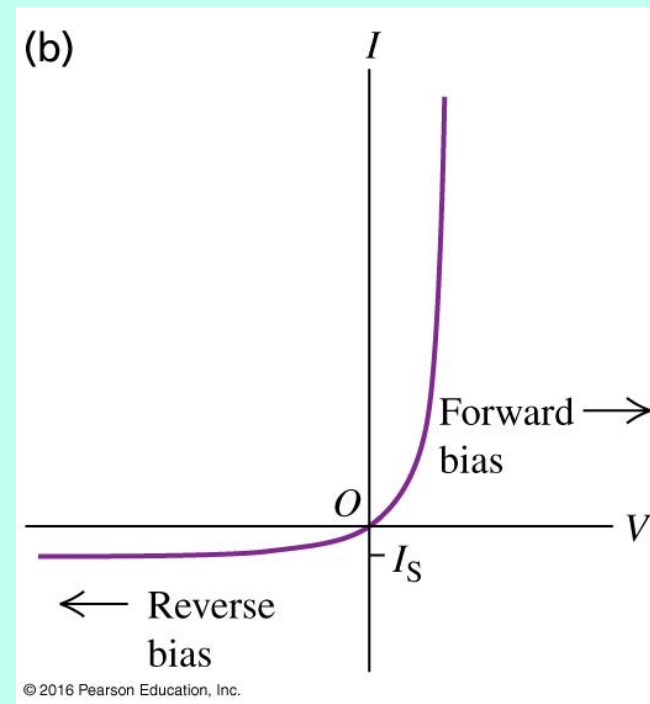
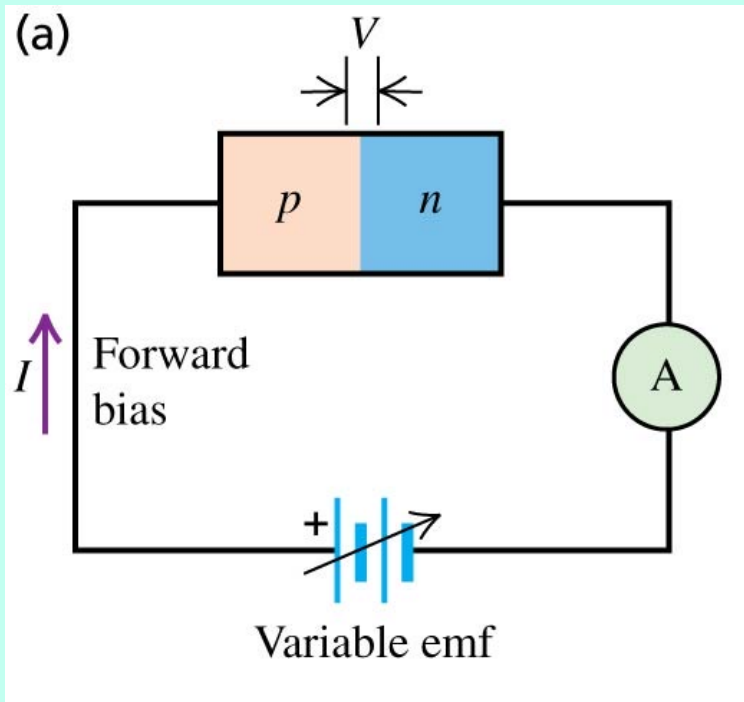

如此則通電時，方向不同，
結果完全不同！

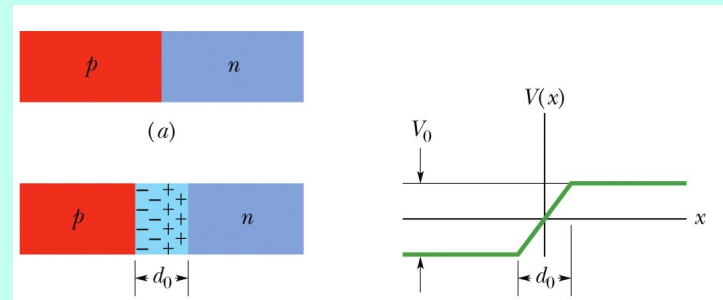

順向 Forward Bias

電子越過n，傳到介面，正好從右邊填補了離開的電子，電子可繼續向左滲透。
因此電子繼續流入p。電流可以流動。

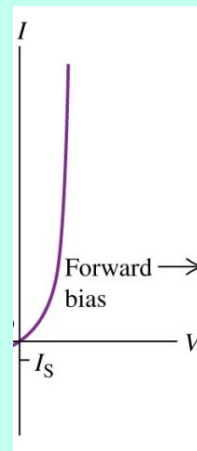
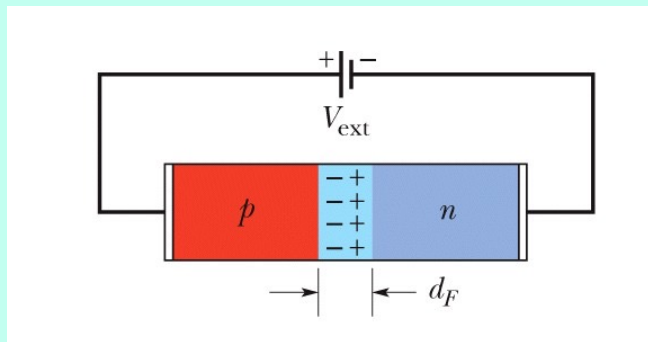

逆向 Reverse Bias

電子越過p，傳到介面，現在卻與從右邊滲透過來的電子擠在一起，搶奪電洞。
介面上的電洞數量有限，電子無法繼續向右傳導。

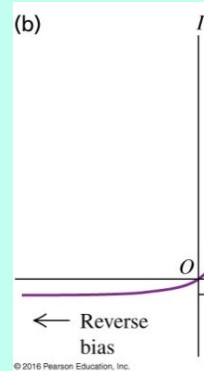
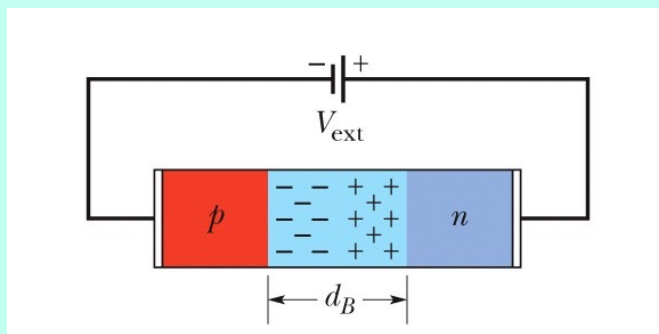

比較精細的推導顯示：二極體的關鍵在p-n介面！

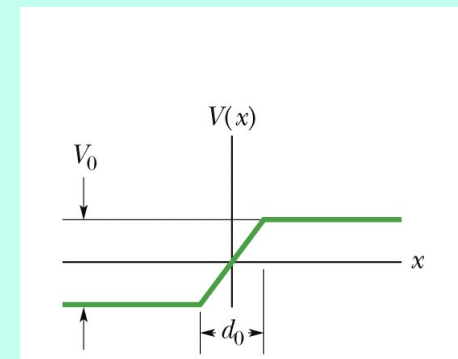
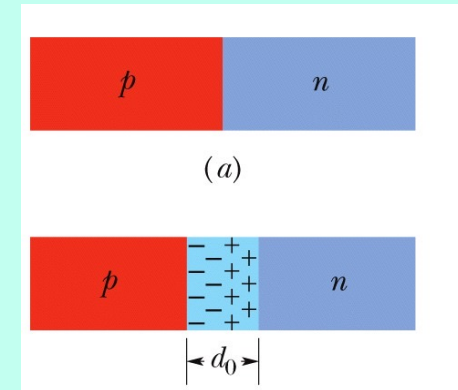
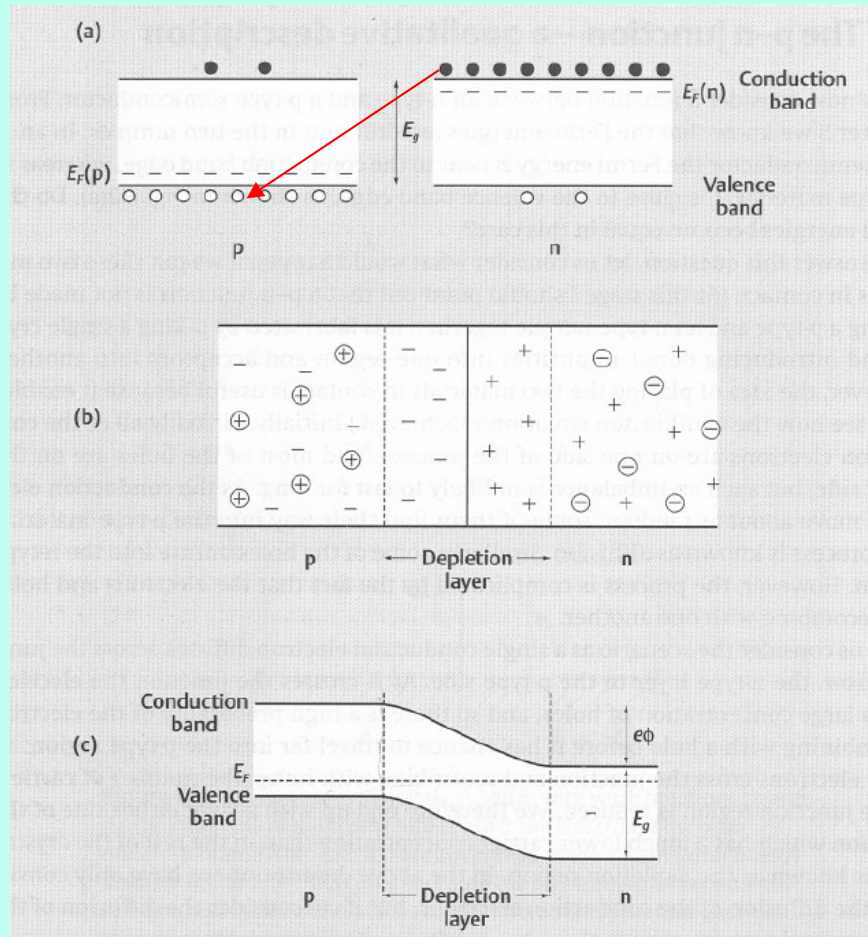

介面上右邊n的電子會滲透進入左邊p，填入電洞之中，因此介面處會形成一層無載體區域，

右邊電子離開後留下正電離子，左邊電子進入帶負電，薄層中會有一向右電場。

因此n與p之間出現電位差！

Depletion Zone產生前：考慮兩種雜質半導體內的電子電洞分佈：

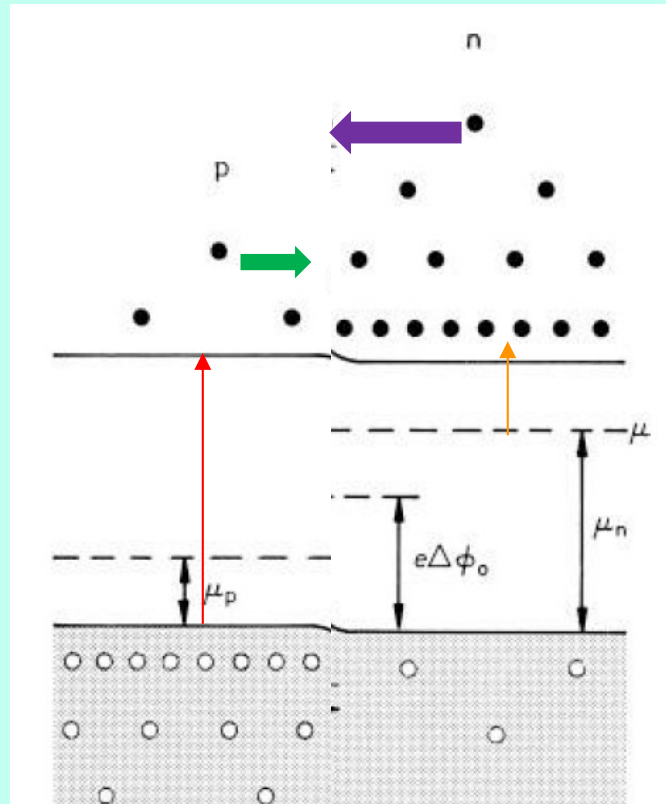

讓我們專注於導帶內電子可能的流動：

左端p，價帶上方少量電子，因熱擾動由價帶跳上傳導帶， $\propto e^{-\frac{E_G}{2kT}}$ 。向右流。 

右端n，Noner內電子，也會因熱到達傳導帶， $\propto e^{-\frac{E_D}{kT}}$ 。間隙較小，電子數量較大。 

因此電子淨向左流，再填入價帶的電洞，如前述，產生了Depletion Zone。

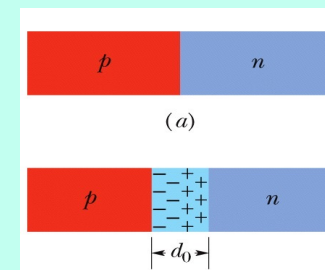
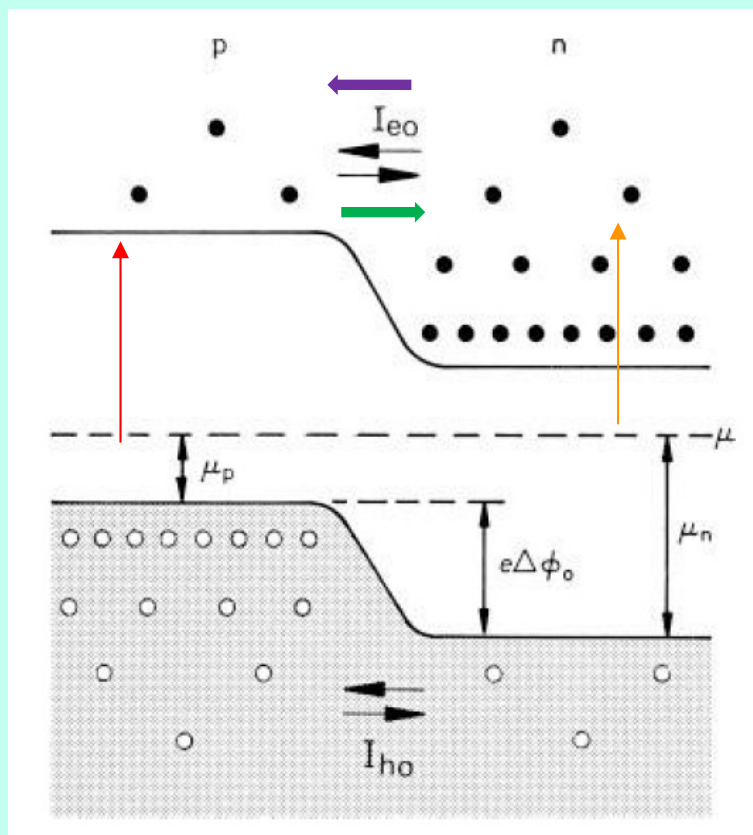

Depletion Zone產生的電子位能差異 $\Delta\phi$ ，應該加在兩端n與p的能帶圖上：

左右兩端導帶的能量高度出現差距，也就是 $\Delta\phi$ 構成了一個障礙。

現在右端n的導帶電子，必須跳上到達左邊導帶的能高，才能往左流。←

向左電流變小，但向右電流並不被影響。→

$\Delta\phi$ 累積到使到達左邊導帶高，兩邊電子數量相同，電流就會抵消而達到穩定。

可以說Depletion Zone出現的電位差，阻止了電子由右向左的擴散繼續進行。

現在p-n間加上一順向的、正的電位差 V ，在介面左右能量差將縮小，如下圖：

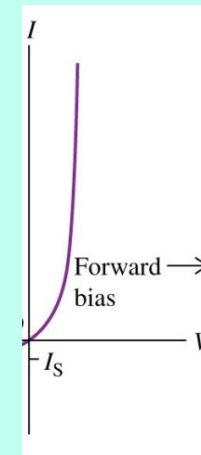
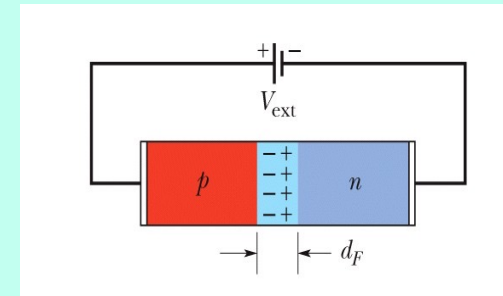
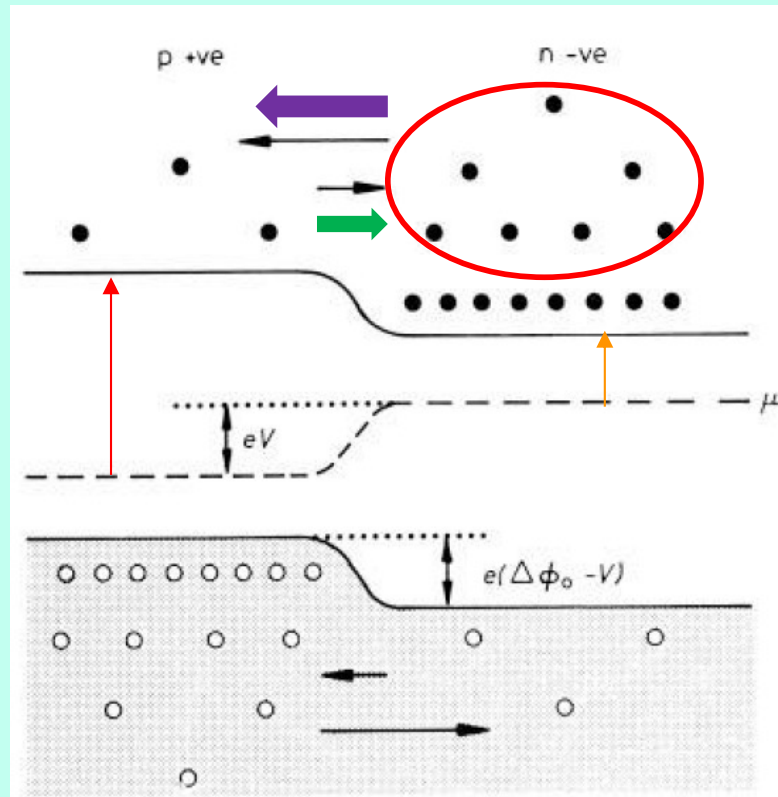

左端p的價帶上方電子，依舊不受所加電壓影響。

右端n的導帶下方，因熱達到左邊導帶能高的電子增加！

就是電子要跨越的門檻能差因加電壓變小，

在導帶上電子的能量分佈是波茲曼分佈 $\sim e^{-(E-E_G)/kT}$ 。

門檻降低 V ，達到的電子數就增加 $\sim e^{V/kT}$ 倍！

因此電子會淨流向左，隨電壓依指數增加的電流向右流。

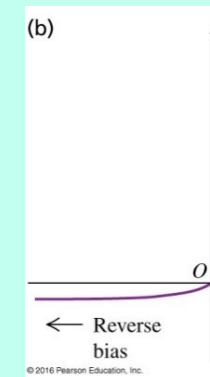
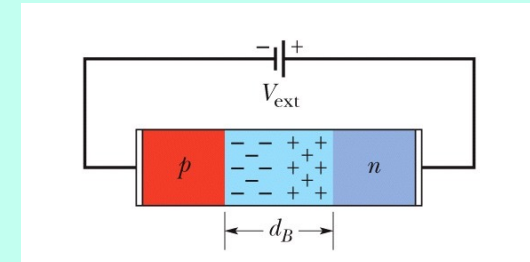
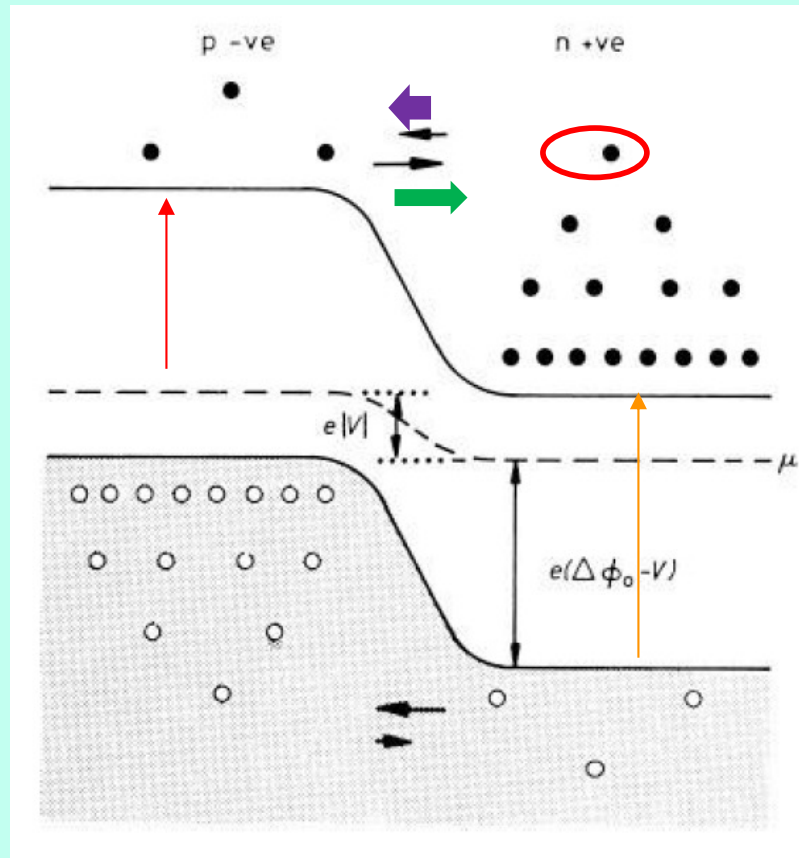

若p-n間加上一負的反向電位差，左右能量差加大，

左端p的價帶上方電子，依舊不受所加電壓影響。

右端n的導帶下方，因熱達到左邊導帶能高的電子則因門檻增加而減少！

因此電子會淨流向右，但只剩下半導體原來因室溫擾動產生的很小的導電度。



電流只能朝單一方向流動！稱為整流器。

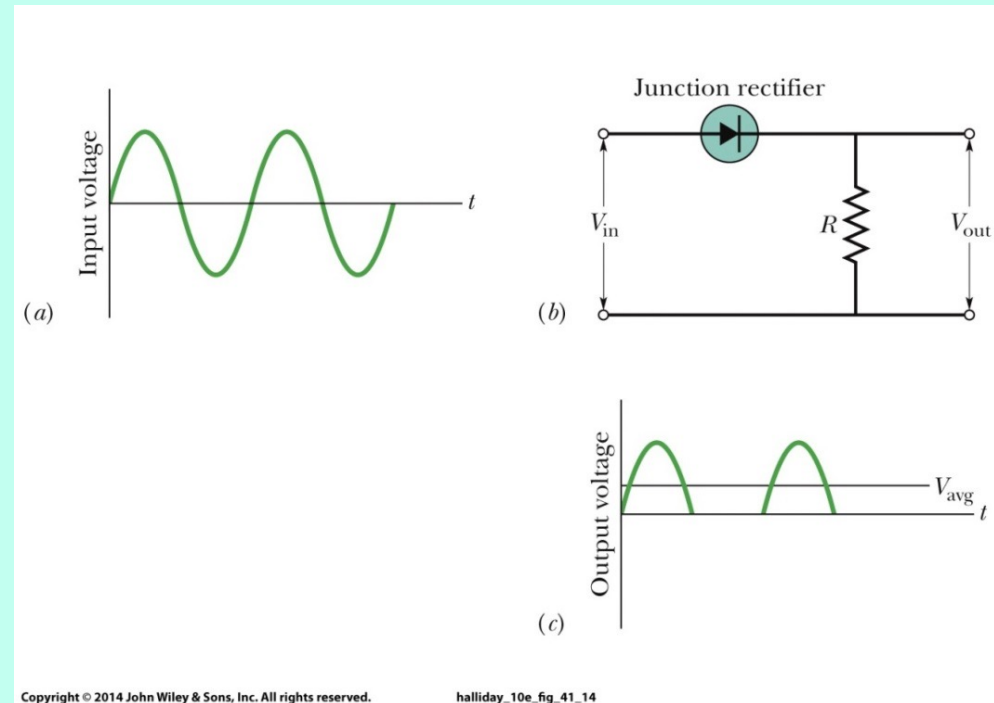
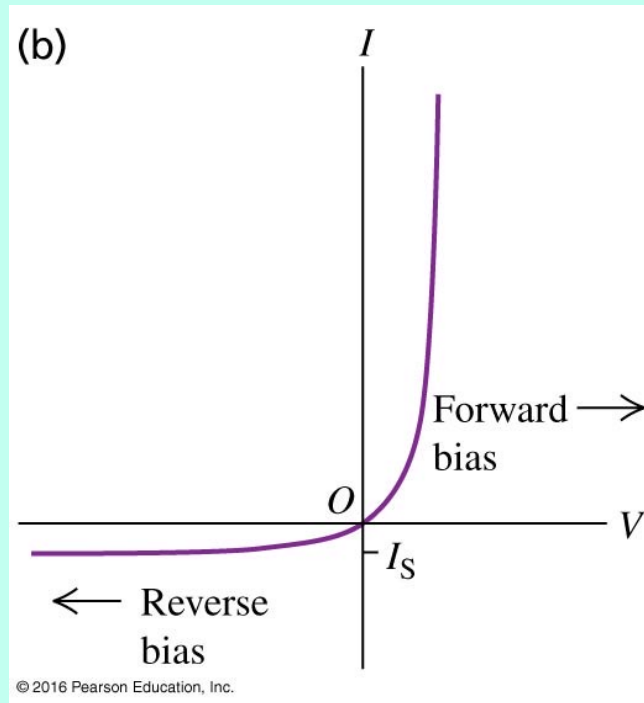

注意n-p介面中，n與p之間會有電位差！。

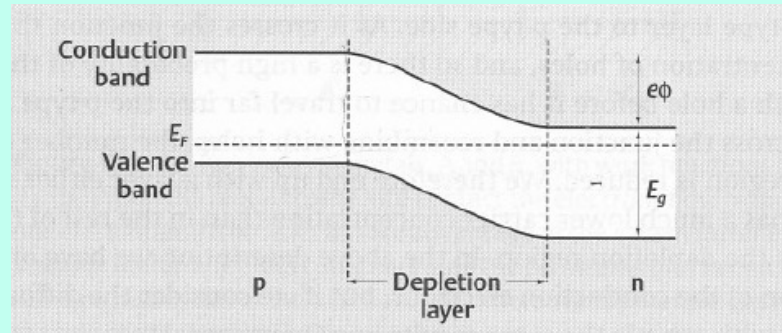

如果對p內輸入傳導電子，他們可以大量地流入n。

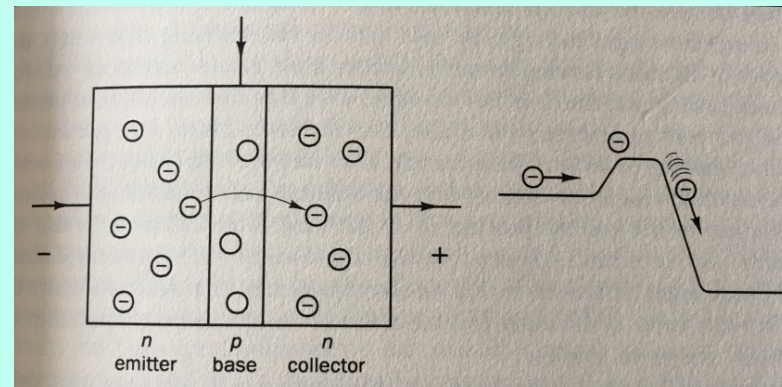

如果在p的左邊再放一個n，並施以順向電壓，
傳導電子就可以由左邊的n大量地流入p，再大量流入右邊n。

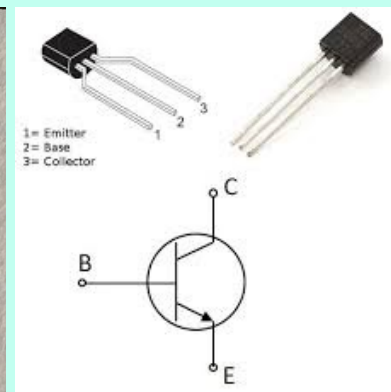
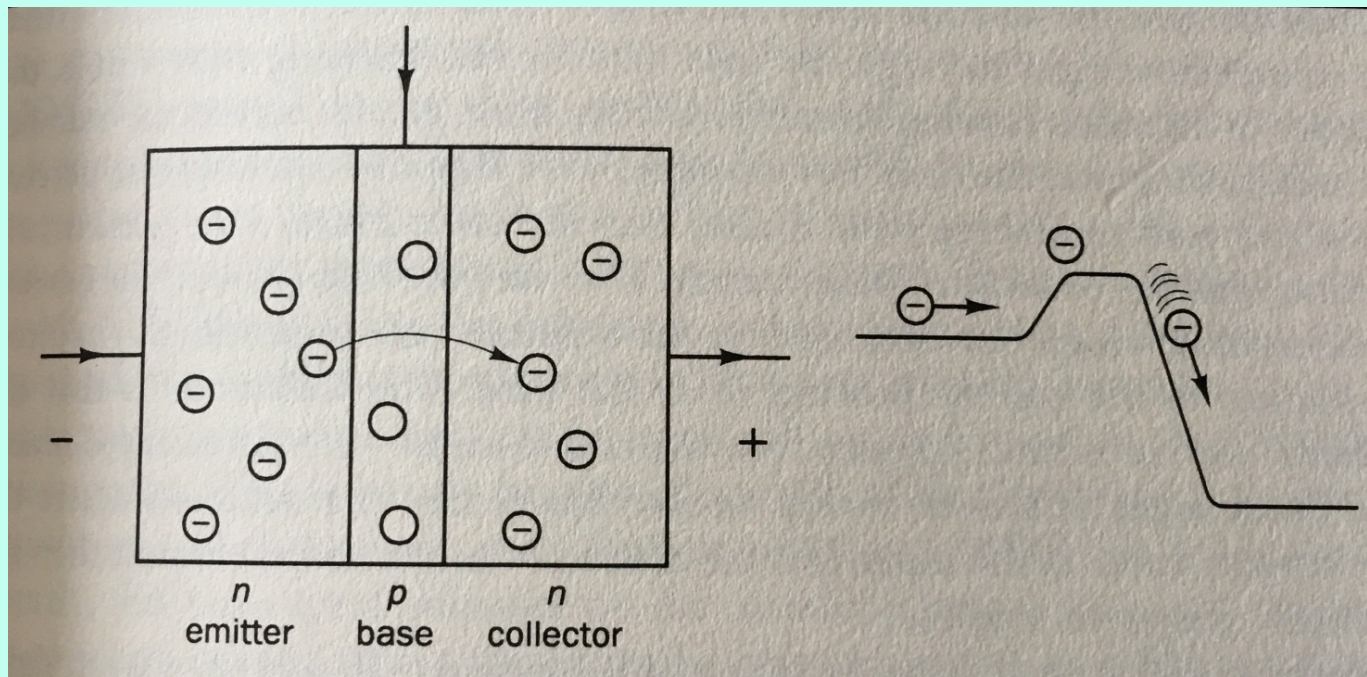
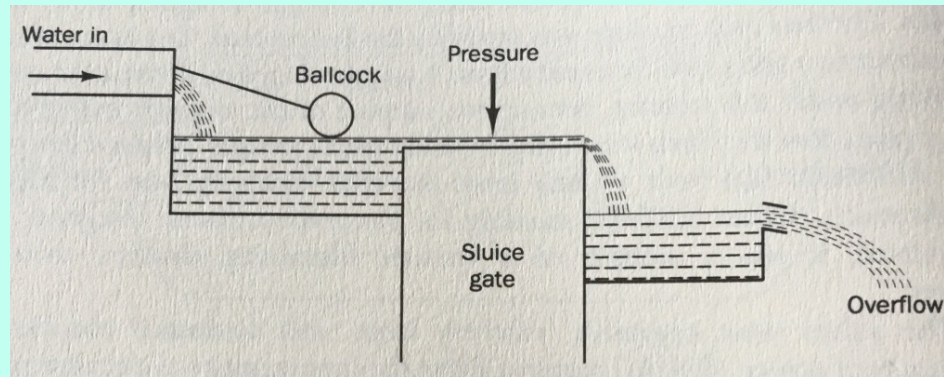

左邊的二極體的順向電壓控制流到p的電子，也就控制了流到右邊n的電流大小。

Bipolar Transistor 雙極性電晶體

電晶體 transistor

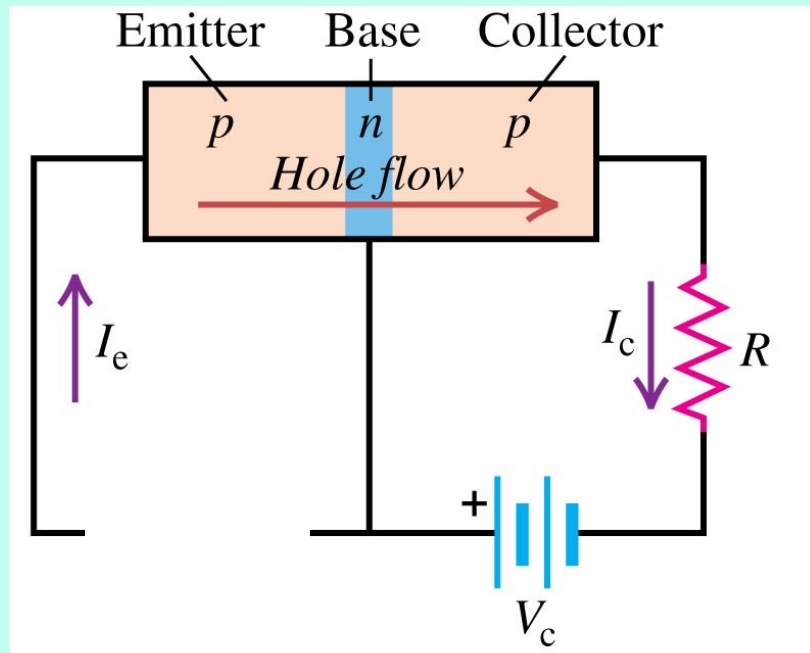

- When $V_e = 0$, the current is very small.
- When a potential V_e is applied between emitter and base, holes travel from the emitter to the base.
- When V_c is sufficiently large, most of the holes continue into the collector.

© 2016 Pearson Education, Inc.

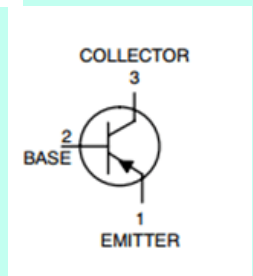

右邊是一個Reverse Bias的電壓 V_c ，電子進到Collector的p，在介面遇左方來的電子，電子無法繼續往左由流入n，因此 I_c 很小。

但如果左方加一個電壓 V_e ，電子會由Base的n被抽走進入Emitter，

如此Collector來的，到介面上電子被電壓 V_c 推動，就能由繼續流入Base，產生 I_c 。

如此以電壓 V_e 做為條件，來控制電壓 V_c 是否能產生 I_c 。

如果電壓 V_e 很小而且有訊號，電壓 V_c 很大，所產生的大 I_c 就會攜帶訊號。

這就是訊號放大器！

audio amplifier 音響放大器

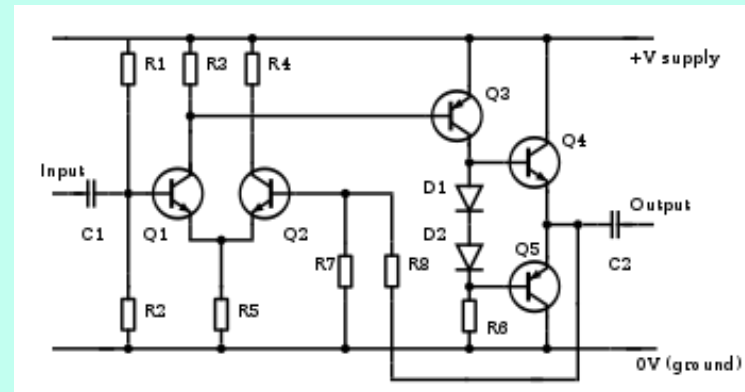
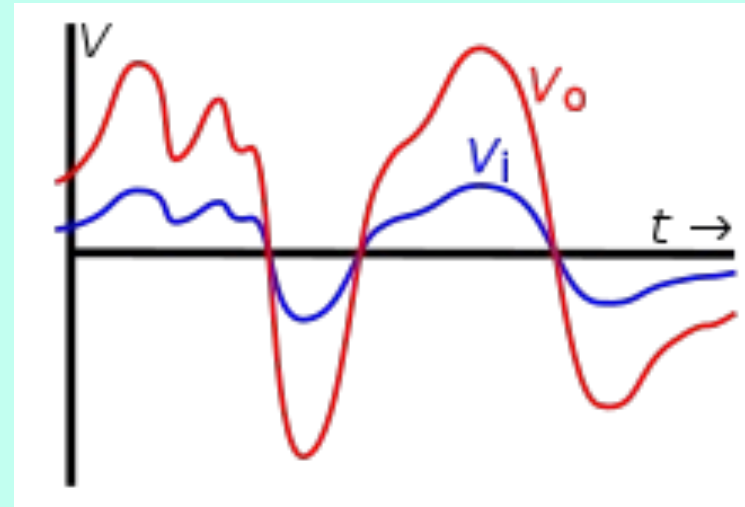

金屬氧化物半導體、場效型電晶體 MOSFET

Metal-Oxide-Semiconductor Field Effect Transistor

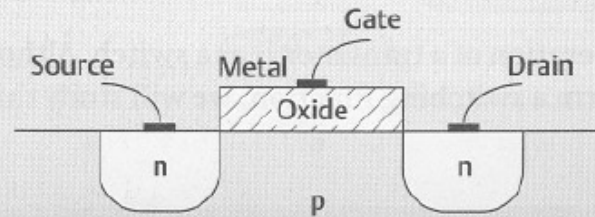

Figure 6.10 The structure of an n-channel MOSFET showing the source, gate and drain region. The electrical contact to the gate is separated from the semiconductor by a thin layer of insulator, typically silicon dioxide.

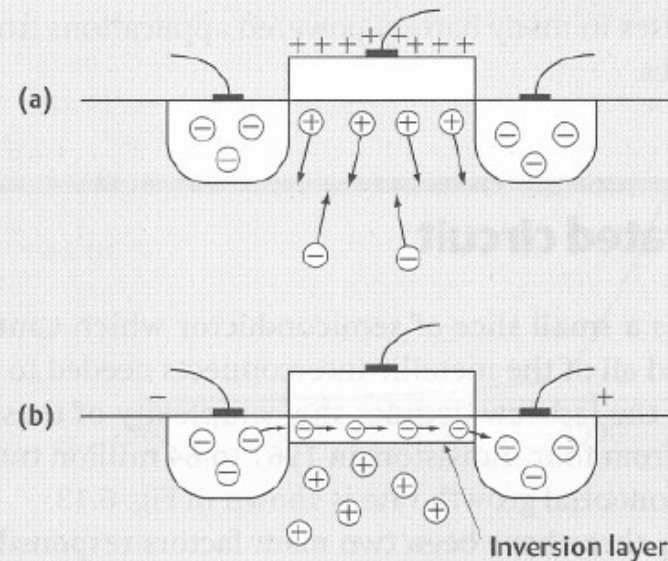
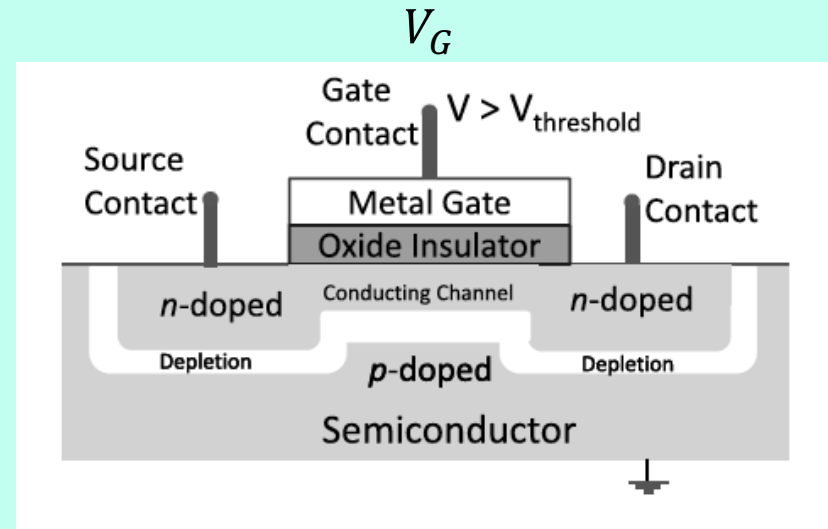
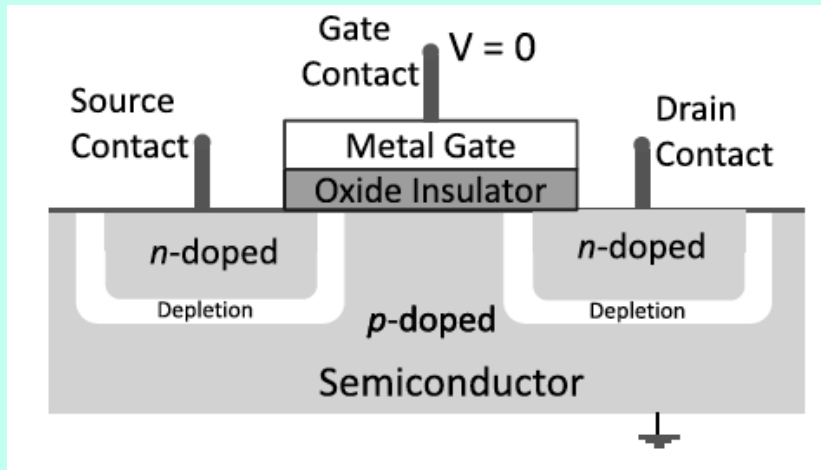
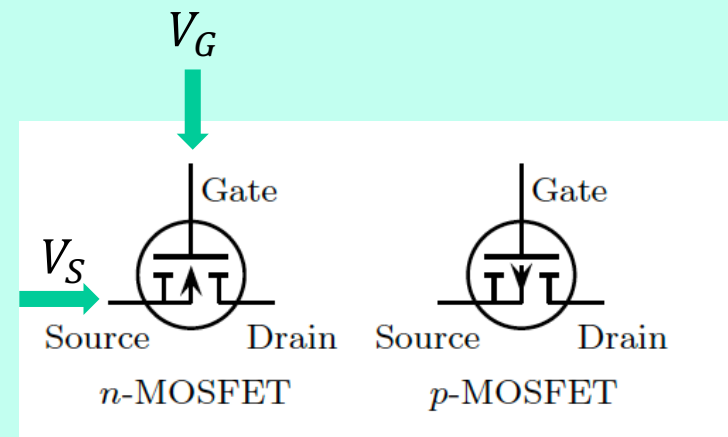
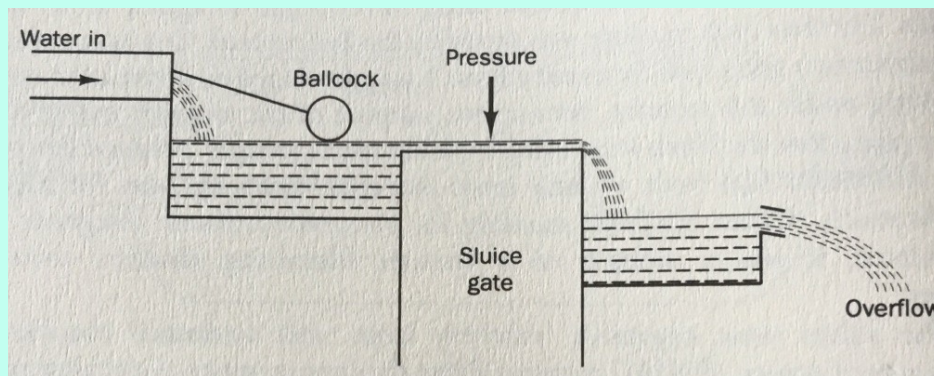

Figure 6.11 (a) When a positive voltage is applied to the gate the holes in the p-type semiconductor are repelled from the surface, and the minority carrier conduction electrons are attracted to the surface. (b) If the gate voltage exceeds the threshold value then an inversion layer is created near the surface. In this layer the material behaves as an n-type semiconductor and so provides a conducting channel between the source and the drain.



如此以閘電壓 V_G 做為條件，來控制電壓 V_S 是否能產生 I_S 。

如果電壓 V_G 很小而且有訊號，電壓 V_S 很大，所產生的大 I_S 就會攜帶訊號。



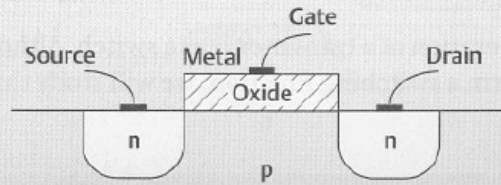
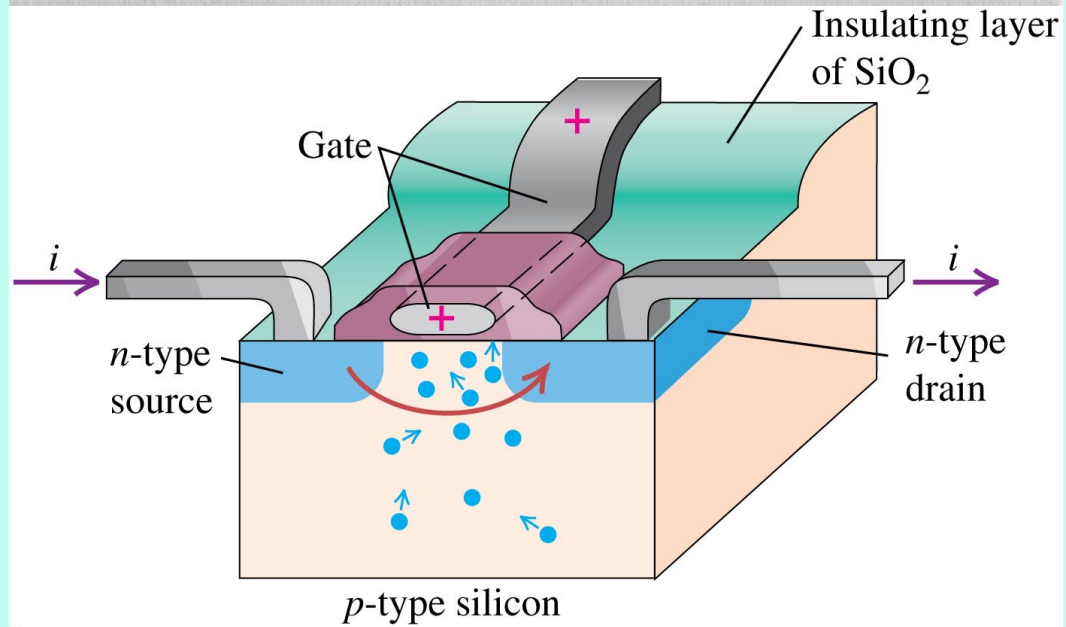

Figure 6.10 The structure of an n-channel MOSFET showing the source, gate and drain region. The electrical contact to the gate is separated from the semiconductor by a thin layer of insulator, typically silicon dioxide.



© 2016 Pearson Education, Inc.

Integrated Circuit 積體電路

Logical Gates

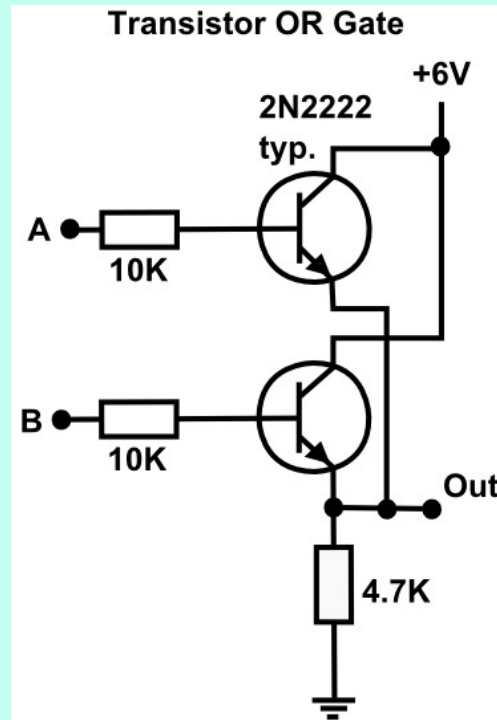
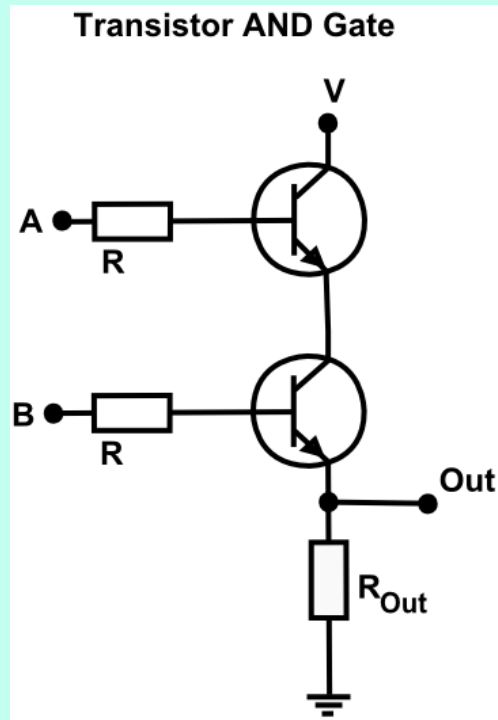

Input		Output
A	B	A XOR B
0	0	0
0	1	1
1	0	1
1	1	0

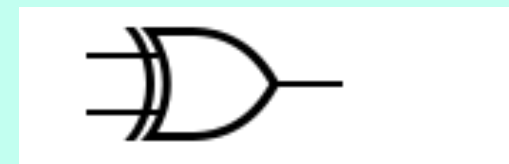
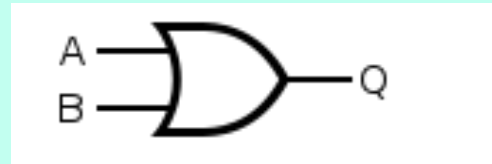
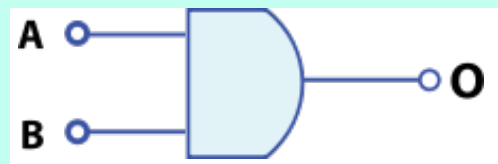

電晶體可以組成邏輯閘門！

邏輯閘門可以組成演算電路！

Half adder logic circuits

